

NUMBER C-1734047
METRIC
3RD ANGLE PROJECTION

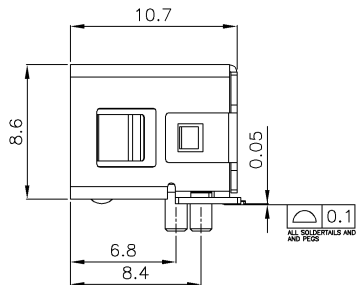
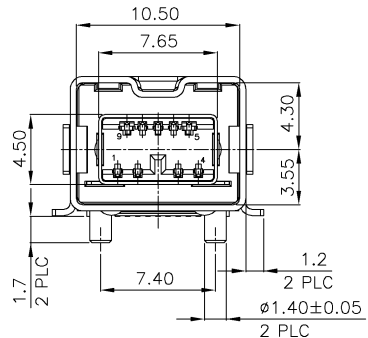
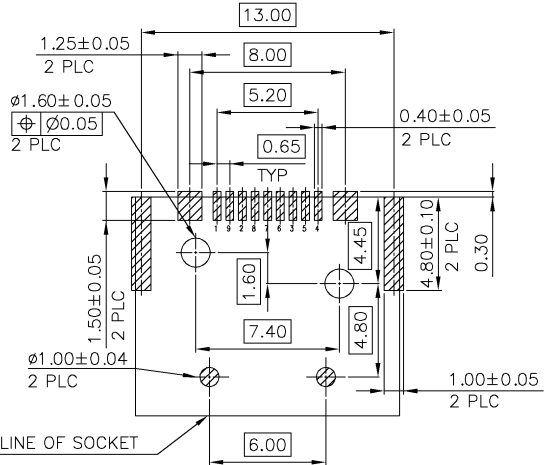
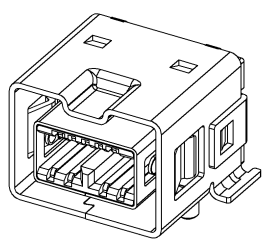
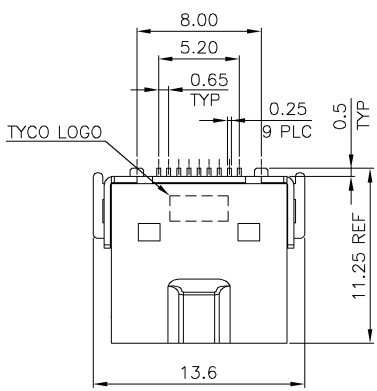

- NOTES:
- MATERIAL:
HOUSING : THERMOPLASTIC HIGH TEMP., UL94V-0, COLOR: BLACK
CONTACT : BRASS, THICKNESS=0.25mm.
INNER SHELL : PHOSPHOR BRONZE, THECKNESS=0.20mm.
OUTER SHELL : PHOSPHOR BRONZE, THECKNESS=0.40mm.
 - FINISH :
CONTACT : 30u" MIN. GOLD PLATED ON CONTACT AREA,
100u" MIN. TIN-Cu PLATING ON SOLDERTAILS,
50u" MIN. NICKEL UNDERPLATED ALL OVER.
INNER SHELL : 120u" MIN TIN-Cu UNDERPLATED ALL OVER.
OUTER SHELL : 120u" MIN TIN-Cu UNDERPLATED ALL OVER.
 - REFLOW SOLDER CAPABLE TO 260°C PER TYCO SPEC 109-201, CONDITION B.

THIS INFORMATION IS CONFIDENTIAL AND IS RELEASED TO YOU ON CONDITION THAT NO FURTHER DISCLOSURE IS MADE BY YOU TO OTHER THAN AMP PERSONNEL WITHOUT DIMENSIONS IN MILLIMETERS. DO NOT SCALE PRINT.

1734047-1
PART NUMBER

TOLERANCES UNLESS OTHERWISE SPECIFIED: 0 PLC ± 0.38 1 PLC ± 0.25 2 PLC ± 0.20 3 PLC ± 0.05 ANGLES ± 3°	DWN	O. HU 12-AUG-2005	tyco Electronics NAME	TYCO HOLDINGS (BERMUDA) VII LTD. TAIWAN BRANCH	
	CHK	S. HOU 12-AUG-2005			
MATERIAL	APVD	W.J. KE 12-AUG-2005	IEEE 1394-B, R/A, SMT TYPE		
SEE NOTE	PRODUCT SPEC	108-57567	LOC	SIZE	DRAWING NO
FINISH	QUALIFICATION TEST REPORT	501-57657	DW	A ₃	C-1734047
SEE NOTE	WEIGHT		SCALE		SHEET
					1 OF 2

0	FIRST RELEASED	OH	18AUG
LTR	REVISION RECORD	DWN	2005
		CHK	DATE

CUSTOMER DRAWING

NUMBER C-1734047
 3RD ANGLE PROJECTION
 METRIC

PRINT DW
 THIS INFORMATION IS CONFIDENTIAL AND IS RELEASED TO YOU ON THE CONDITION THAT NO FURTHER DISCLOSURE IS MADE BY YOU TO OTHER THAN AMP PERSONNEL WITHOUT DIMENSIONS IN MILLIMETERS. DO NOT SCALE PRINT.

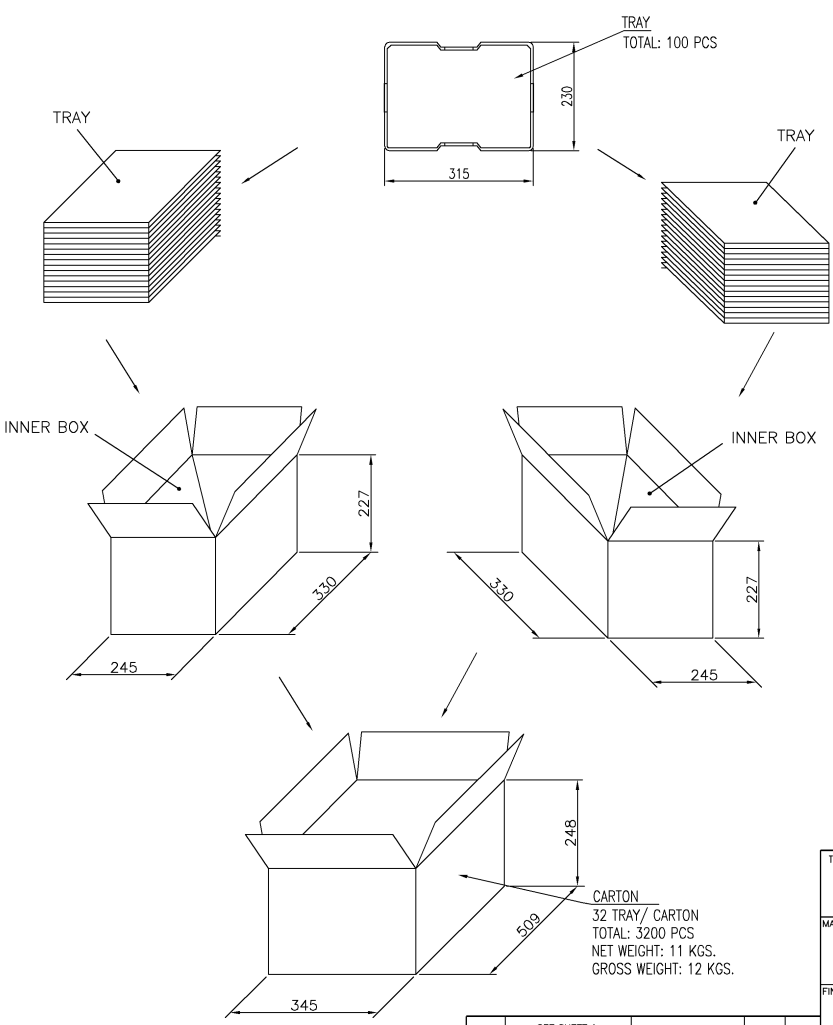

SEE SHEET 1.				
LTR	REVISION RECORD	ECN	DWN/CHK	DATE

TOLERANCES UNLESS OTHERWISE SPECIFIED: 0 PLC ± 1 PLC ± 2 PLC ± 3 PLC ± ANGLES ±	DWN O. HU 12-AUG-2005 CHK S. HOU 12-AUG-2005	tyco Electronics TYCO HOLDINGS (BERMUDA) VII LTD. TAIWAN BRANCH
MATERIAL SEE SHEET 1.	APVD W.J. KE 12-AUG-2005 PRODUCT SPEC	NAME IEEE 1394-B, R/A, SMT TYPE
FINISH SEE SHEET 1.	QUALIFICATION TEST REPORT WEIGHT	LOC DW SCALE SIZE A ₃ DRAWING NO C-1734047 REV O SHEET 2 OF 2

CUSTOMER DRAWING 1

D
C
B
A