

NUMBER C-1734144  
METRIC  
3RD ANGLE PROJECTION

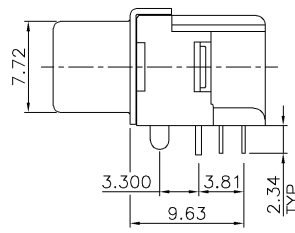

- NOTES:
- MATERIAL:  
HOUSING: THERMOPLASTIC, UL 94V-0 RATED, COLOR: IVORY.  
CONTACT: PHOSPHOR BRONZE, THICKNESS=0.3mm.  
SHELL: SPOC-SD, THICKNESS=0.5mm.  
HOOK: BRASS, THICKNESS=0.5mm.  
NUT: BRASS.
  - FINISH:  
CONTACT: GOLD PLATED(SEE TABLE) ON CONTACT AREA, 100µ" MIN. BRIGHT TIN PLATED ON SOLDERTAILS, 50µ" MIN. NICKEL UNDERPLATED OVERALL.  
SHIELD: 50µ" MIN. NICKEL PLATED.  
HOOK: TIN PLATED.  
NUT: NICKEL PLATED.  
#4-40 UNC SCREW, SCREW HEAD LENGTH: 6.0±0.5mm.  
SCREW SEPARATELY PACKED.
  - WAVE SOLDER CAPABLE TO 240°C PER TYCO SPEC109-202, CONDITION A.
  - OBsolete PARTS: OBSOLETE CIS STREAMLINING PER D.RENAUD/D.SINISI

W/	GOLD FLASH	2-1734144-1
W/	30u"	1-1734144-3
W/	10u"	1-1734144-2
W/O	GOLD FLASH	1-1734144-1
W/O	30u"	1734144-3
W/O	10u"	1734144-2
W/O	GOLD FLASH	1734144-1
SCREW	GOLD PLATED	PART NUMBER

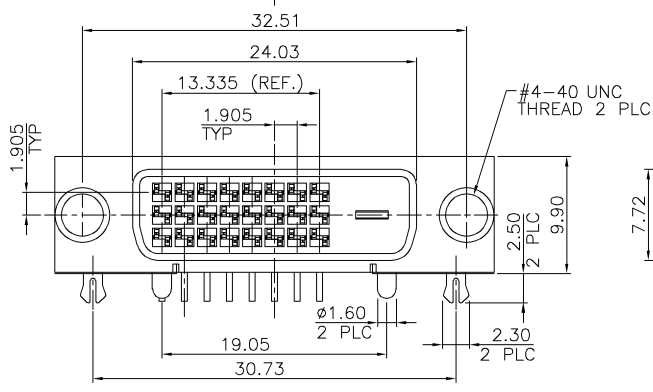
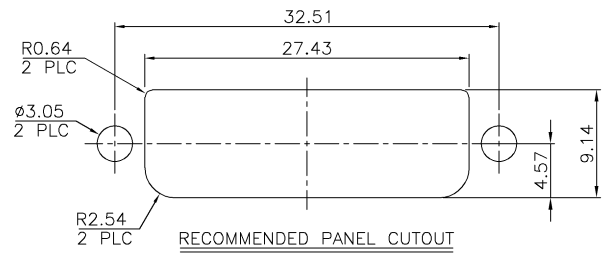
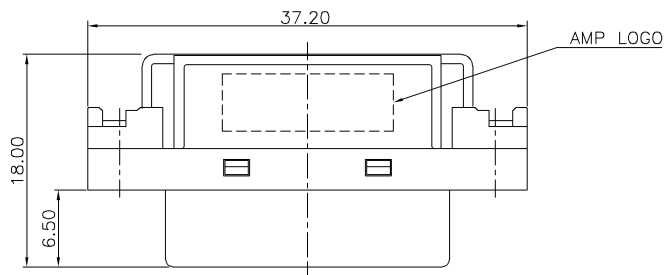
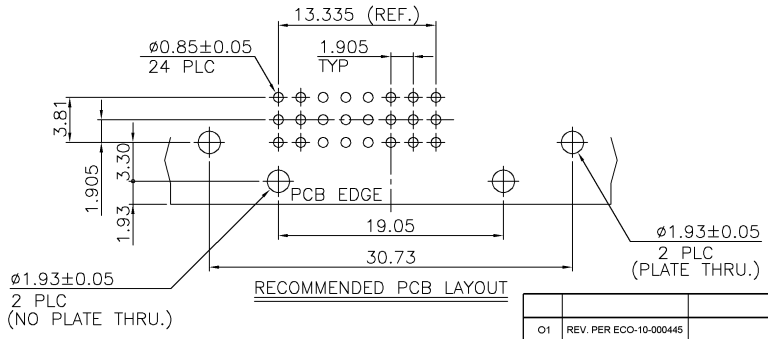

TOLERANCES UNLESS OTHERWISE SPECIFIED:		DWN	O. HU	tyco	TYCO HOLDINGS (BERMUDA)
0 PLC ±		08-JUL-2005	08-JUL-2005	Electronics	VII LTD, TAIWAN BRANCH
1 PLC ± 0.20		CHK	S. HOU	NAME	
2 PLC ± 0.20			08-JUL-2005		
3 PLC ± 0.10					
ANGLES ± 3°					
MATERIAL	SEE NOTE	APVD	W.J. KE	DVI-D DIGITAL, RCPT. CONN., RIGHT ANGLE	
		PRODUCT SPEC	08-JUL-2005		
		108-1941			
FINISH	SEE NOTE	APPLICATION SPEC		LOC	SIZE
				DW	A <sub>3</sub>
		WEIGHT		SCALE	DRAWING NO
					C-1734144
					REV
					O1
					SHEET
					1 OF 2

THIS INFORMATION IS CONFIDENTIAL AND IS PROVIDED TO YOU ON THE CONDITION THAT NO PARTS OR INFORMATION HEREIN IS TO BE REPRODUCED OR TRANSMITTED IN ANY FORM OR BY ANY MEANS, WITHOUT PERMISSION IN WRITING FROM TYCO ELECTRONICS. DIMENSIONS IN MILLIMETERS. DO NOT SCALE PRINT.

PRINT DW  
DWB

8 7 6 5 4 3 2 1 CUSTOMER DRAWING

O1	REV. PER ECO-10-000445	KK	11JAN10
0	FIRST RELEASED	OH	15JUL 2005
LTR	REVISION RECORD	DWB	CHK DATE

NUMBER  
C-1734144

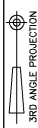

METRIC

THIS INFORMATION IS CONFIDENTIAL AND IS DISCLOSED TO YOU ON A CONDITION THAT NO FURTHER DISCLOSURE IS MADE BY YOU TO OTHER THAN AMP PERSONNEL WITHOUT DIMENSIONS IN MILLIMETERS. DO NOT SCALE PRINT.

PRINT DIST  
DW

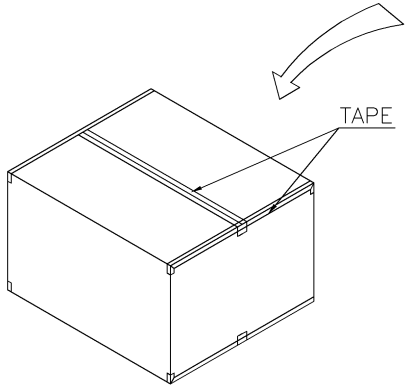
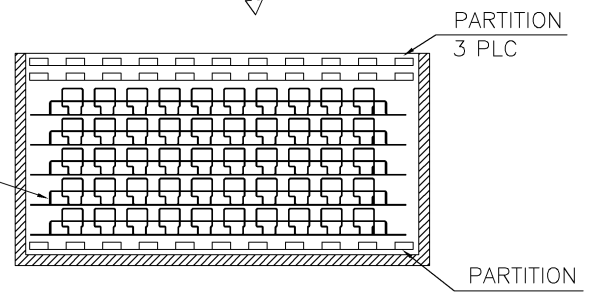
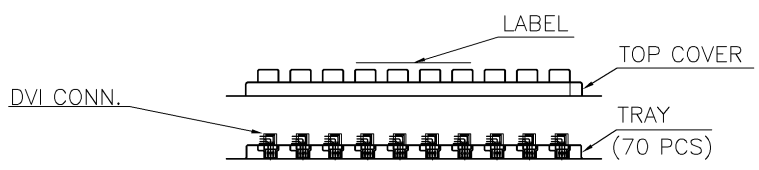

3.55	2.63	340X278X146	340X275X19.6	350
G.W./CARTON	N.W./CARTON	CARTON SIZE	TRAY SIZE	QUANTITY

TOLERANCES UNLESS OTHERWISE SPECIFIED: 0 PLC ± 1 PLC ± 2 PLC ± 3 PLC ± ANGLES ±	DWN	O. HU 08-JUL-2005	<b>tyco</b> <b>Electronics</b> TYCO HOLDINGS (BERMUDA) VII LTD. TAIWAN BRANCH
	CHK	S. HOU 08-JUL-2005	
MATERIAL	APVD	W.J. KE 08-JUL-2005	NAME
SEE NOTE	PRODUCT SPEC	-	DVI-D DIGITAL, RCPT. CONN., RIGHT ANGLE
FINISH	APPLICATION SPEC	-	LOC
SEE NOTE	WEIGHT	-	SIZE
			DRAWING NO
			C-1734144
			REV
			O1
			SCALE
			---
			SHEET
			2 OF 2

SEE SHEET 1.	ECN	DWN/CHK	DATE
LTR	REVISION RECORD		

CUSTOMER DRAWING

8 7 6 5 4 3 2 1

D  
C  
B  
A