

NUMBER C-1734091

METRIC

PRINT DIST DW

THIS INFORMATION IS CONFIDENTIAL AND IS DISCLOSED TO YOU ON CONDITION THAT NO FURTHER DISCLOSURE IS MADE BY YOU TO OTHER THAN AMP PERSONNEL WITHOUT THE WRITTEN PERMISSION OF AMP. DIMENSIONS IN MILLIMETERS. DO NOT SCALE PRINT.

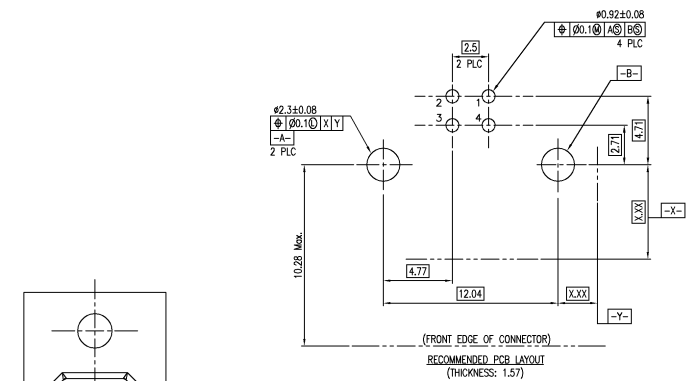
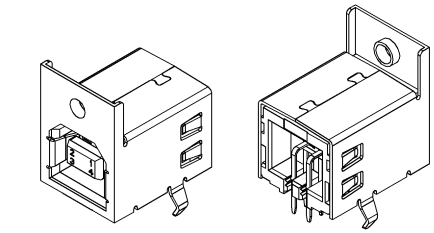
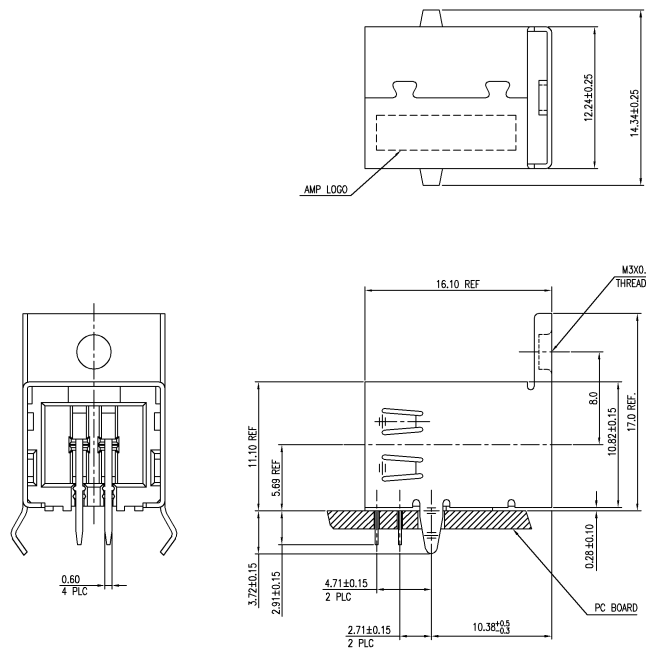

- NOTE:
- MATERIAL:
HOUSING: THERMOPLASTIC, UL 94V-0, COLOR: BLACK.
CONTACTS: PHOSPHOR BRONZE, THICKNESS=0.25mm.
SHELL: PHOSPHOR BRONZE, THICKNESS=0.4mm.
 - FINISH:
CONTACT : 30u" MIN. GOLD PLATED ON CONTACT AREA,
80u" MIN. TIN-Cu PLATED ON SOLDER TAILS,
50u" MIN. NICKEL PLATED UNDERPLATED ALL. OVER.
SHELL : 200u" MIN. TIN PLATED OVER 50u" MIN. NICKLE.
 - SPECIFICATIONS:
TORQUE STRENGTH: 3Kg-cm MIN.
ALLOW FOR A PANEL THICKNESS OF 2.67MM MAX., IF THE RECEPTACLE CONNECTOR IS MOUNTED BEHIND A PANEL.
 - X.XX DIMENSIONS ESTABLISHED BY CUSTOMER.
 - WAVE SOLDER CAPABLE TO 240°C PER TYCO SPEC 109-202, CONDITION A.

A	REVISED DRAWING	ECR-05-001814	OH	09-SEP-2005
O	FIRST RELEASED	FZ00-0164-04	OH	23-JUL-2004
LTR	REVISION RECORD	ECN	DWN	CHK

TOLERANCES UNLESS OTHERWISE SPECIFIED:		DWN	O. HUI	tyco	TYCO HOLDINGS (BERMUDA)
0	PLC ±0.38	CHK	08-SEP-2005	Electronics	VII LTD. TAIWAN BRANCH
1	PLC ±0.25	S. HOU		NAME	
2	PLC ±0.13	08-SEP-2005		USB CONN., RIGHT ANGLE, SHIELD, FLANGE, B TYPE	
3	PLC ±0.05	APVD		W.J. KE	
ANGLES ±3°		PRODUCT SPEC		108-57085	
SEE NOTE		QUALIFICATION TEST REPORT		501-57043	
SEE NOTE		WEIGHT		SCALE	
		LOC		SIZE	
		DW		A ₃	
		DRAWING NO		C-1734091	
		REV		A	
		SHEET		1 OF 2	

CUSTOMER DRAWING

NUMBER C-1734091



METRIC

PRINT DIST DW
THIS INFORMATION IS CONFIDENTIAL AND IS DISCLOSED TO YOU ON CONDITION THAT NO FURTHER DISCLOSURE IS MADE BY YOU TO OTHER THAN AMP PERSONNEL WITHOUT DIMENSIONS IN MILLIMETERS. DO NOT SCALE PRINT.

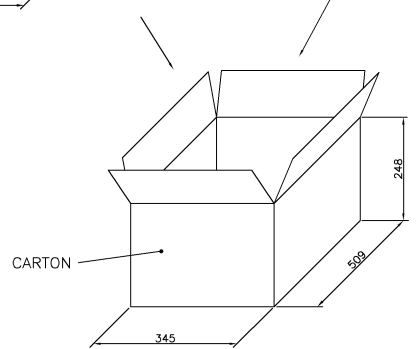
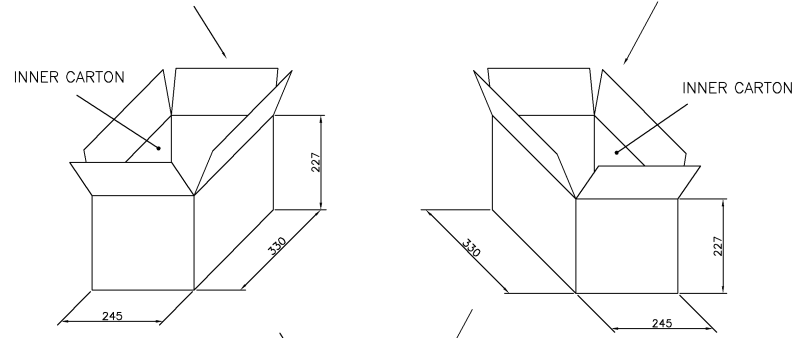
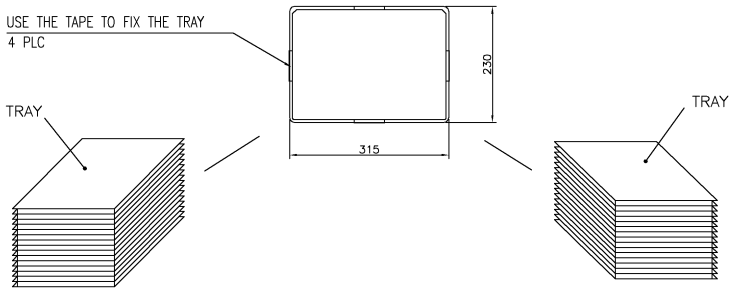

SEE SHEET 1.	ECN	DWN/CHK	DATE
LTR	REVISION RECORD		

12.5	11.5	2400	1200 (12 TRAY)	100
G.W(KGS)	N.W(KGS)	PCS/ OUTER BOX	PCS/ INNER BOX	PCS/ TRAY
TOLERANCES UNLESS OTHERWISE SPECIFIED:		DWN	O. HU	TYCO
0 PLC			08-SEP-2005	TYCO HOLDINGS (BERMUDA)
1 PLC		CHK	S. HOU	VII LTD. TAIWAN BRANCH
2 PLC			08-SEP-2005	NAME
3 PLC				USB CONN., RIGHT ANGLE, SHIELD, FLANGE, B TYPE
ANGLES				
MATERIAL		APVD	W.J. KE	
-			08-SEP-2005	
FINISH		QUALIFICATION TEST REPORT		
-				
WEIGHT		LOC	SIZE	DRAWING NO
		DW	A ₃	C-1734091
		SCALE		SHEET
			--	2 OF 2

CUSTOMER DRAWING