

NUMBER C-1734084
METRIC
3RD ANGLE PROJECTION

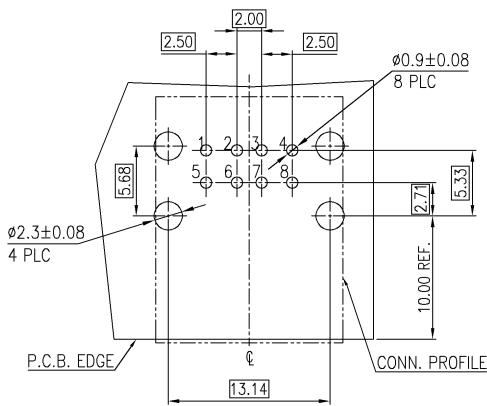

RECOMMENDED P.C.B. LAYOUT (THICKNESS=1.6mm)
(TOP VIEW) (TOLERANCE: ±0.05mm)

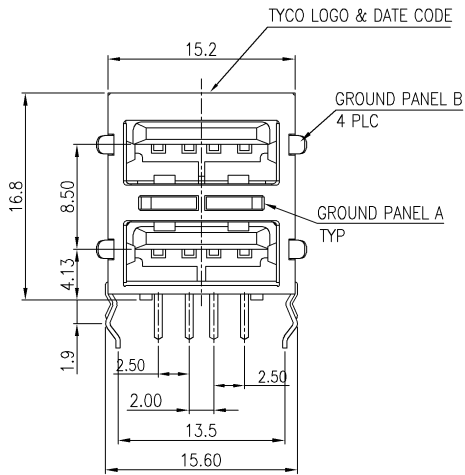
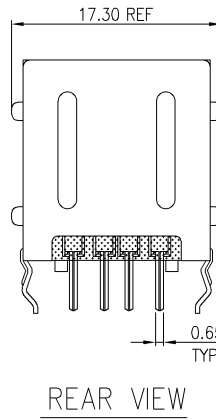
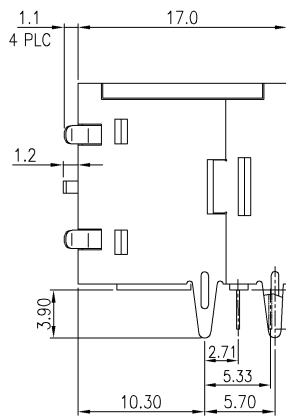

REAR VIEW

NOTES:

- MATERIAL:
HOUSING: THERMOPLASTIC (SEE TABLE), WITH 30% GLASS FIBER FILLED, UL 94V-0 RATED, BLACK COLOR
CONTACT: PHOSPHOR BRONZE, (t=0.25mm)
SHIELD: COLD ROLL STEEL, (t=0.35mm)
GROUNDING STRIP: STAINLESS, (t=0.20 & 0.25mm)
 - FINISH :
CONTACT: 30µ" MIN. GOLD PLATING ON CONTACT AREA.
150µ" MIN. BRIGHT TIN PLATING ON SOLDER TAILS
50µ" MIN. NICKEL UNDERPLATING OVERALL
SHIELD: 120µ" NICKEL PLATED OVER 50µ" MIN Cu
- ⚠ WAVE SOLDER CAPABLE TO 265°C PER TYCO SPEC109-202, CONDITION B.
⚠ REFLOW SOLDER CAPABLE TO 260°C PER TYCO SPEC 109-201, CONDITION B.
⚠ OBSOLETE PARTS: OBSOLETE CIS STREAMLINING PER D.RENAUD/D.SINISI

⚠ PA46	W/	W/O	2-1734084-2
⚠ PBT	W/	W/O	2-1734084-1
⚠ PA46	W/O	W/	1-1734084-2
⚠ PBT	W/O	W/	1-1734084-1
⚠ PA46	W/O	W/O	0-1734084-2
⚠ PBT	W/O	W/O	0-1734084-1

⚠ OBSOLETE

HSG. MATERIAL	GROUND PANEL B	GROUND PANEL A	PART NUMBER
---------------	----------------	----------------	-------------

TOLERANCES UNLESS OTHERWISE SPECIFIED: 0 PLC ± 1 PLC ± 0.35 2 PLC ± 0.25 3 PLC ± ANGLES ±	DWN	O. HU	 TYCO HOLDINGS (BERMUDA) VII LTD, TAIWAN BRANCH NAME
	CHK	S. JOU	
MATERIAL	APVD	W.J. KE	RCPT, STACKED, USB, R/A, A TYPE
SEE NOTE	PRODUCT SPEC	07-JUL-2005	
SEE NOTE	QUALIFICATION TEST REPORT	501-57638	LOC DW
	WEIGHT	6.16g	SIZE A ₃
			DRAWING NO C-1734084
			REV A1
			SCALE --
			SHEET 1 OF 2

A1	REVISED PER	ECO-10-000445	KK AEG	11JAN10
A	REVISED DWG	ECR-05-006389	OH SH	08JUL 2005
0	FIRST RELEASED		OH SH	13MAY 2005
LTR	REVISION RECORD	ECN	DWN CHK	DATE

PRINT DW

8 7 6 5 4 3 2 1 CUSTOMER DRAWING

THIS INFORMATION IS CONFIDENTIAL AND IS RELEASED TO YOU ON THE CONDITION THAT NO FURTHER DISCLOSURE OR REPRODUCTION OF THIS INFORMATION IS MADE BY YOU TO OTHER THAN AMP PERSONNEL WITHOUT THE WRITTEN PERMISSION OF AMP. DIMENSIONS IN MILLIMETERS. DO NOT SCALE PRINT.

THIS INFORMATION IS CONFIDENTIAL AND IS RELEASED TO YOU ON CONDITION THAT NO FURTHER DISCLOSURE IS MADE BY YOU TO OTHER THAN AMP PERSONNEL WITHOUT DIMENSIONS IN MILLIMETERS. DO NOT SCALE PRINT.

PRINT DW
 DW

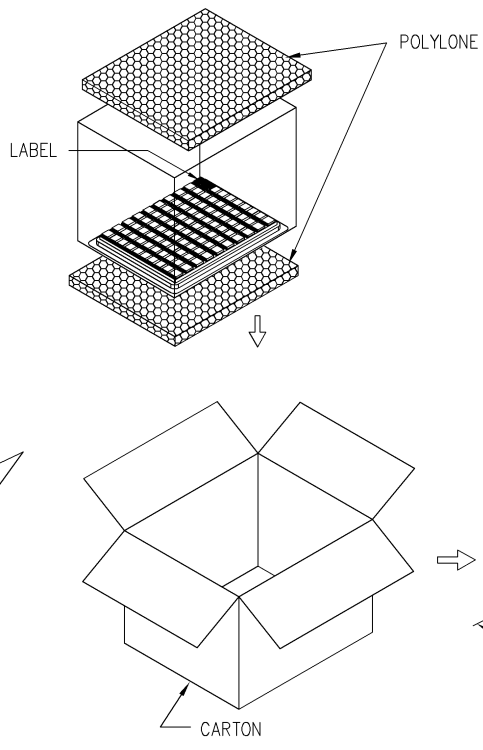
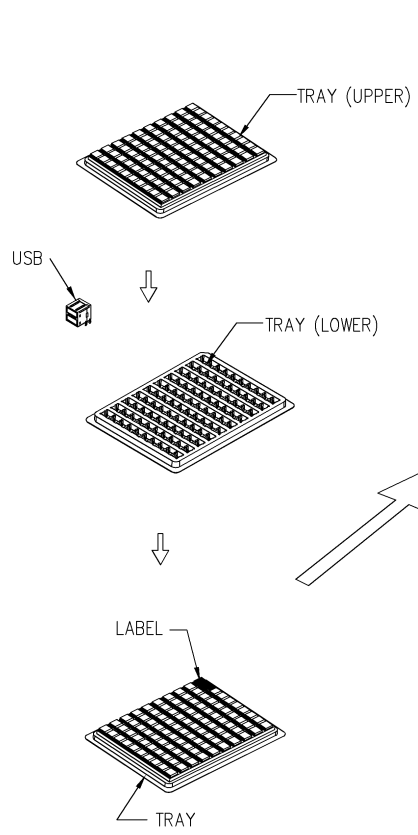

- NOTES:
- MATERIAL:
 TRAY: PS.
 POLYLONE:POLYLONE
 SHIPPING CARTON: CORRUGATED FIBER.
 - DIMENSION :
 TRAY : L=307mm, W=235mm, H=24mm
 SHIPPING CARTON : L=325mm, W=256mm, H=285mm
 POLYLONE : L=305mm, W=236mm, H=11.5mm
 - QUANTITY :
 100 PCS/TRAY
 10 TRAYS/SHIPPING CARTON(1,000PCS)
 - WEIGHT :
 NET WEIGHT : 6.50 KG
 GROSS WEIGHT : 7.80 KG

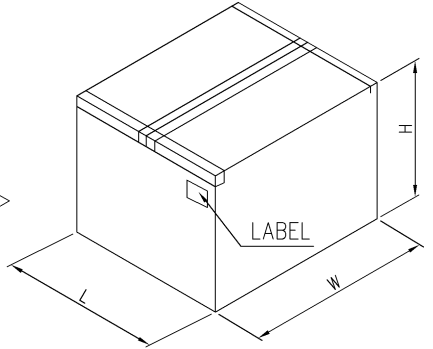

SEE SHEET 1.	ECN	DWN/CHK	DATE
LTR	REVISION RECORD		

TOLERANCES UNLESS OTHERWISE SPECIFIED: 0 PLC ± 1 PLC ± 2 PLC ± 3 PLC ± ANGLES ±	DWN O. HU 07-JUL-2005 CHK S. JOU 07-JUL-2005	tyco Electronics NAME TYCO HOLDINGS (BERMUDA) VII LTD. TAIWAN BRANCH
MATERIAL SEE NOTE	APVD W.J. KE 07-JUL-2005 PRODUCT SPEC --	RCPT, STACKED, USB, R/A, A TYPE
FINISH SEE NOTE	QUALIFICATION TEST REPORT --	LOC DW SIZE A ₃ DRAWING NO C-1734084 SCALE --
		REV A1 SHEET 2 OF 2

CUSTOMER DRAWING