

NUMBER C-1734176
METRIC
3RD ANGLE PROJECTION

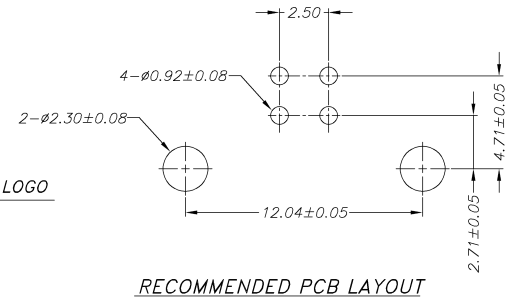

- NOTES :
- MATERIAL :
HOUSING : PBT WITH 30% G.F., 94V-0, COLOR: SEE TABLE.
CONTACT : PHOSPHOR BRONZE, (t=0.25mm).
FRONT SHELL : BRASS, (t=0.30mm).
REAR SHELL : SPCC (t=0.30mm).
 - FINISH :
CONTACT : GOLD PLATED(SEE TABLE) ON CONTACT AREA, 100u" MIN. TIN PLATED ON SOLDERTAILS, 50u" MIN. NICKEL UNDERPLATED ALL OVER.
FRONT SHELL: 40u" MIN. NICKEL PLATED OVER 50u" MIN. CU UNDERPLATED ALL OVER.
REAR SHELL: 100u" MIN. NICKEL PLATED OVER 100u" MIN. CU UNDERPLATED ALL OVER.

⚠️ OBSOLETE PARTS: OBSOLETE CIS STREAMLINING PER D.RENAUD/D.SINISI

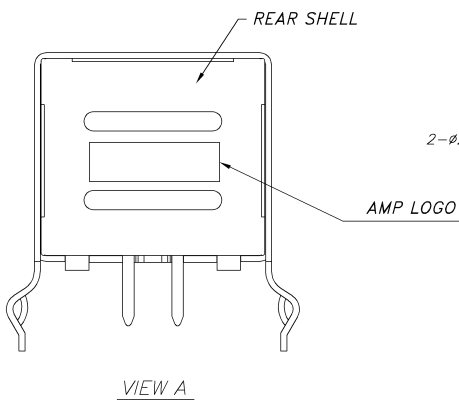
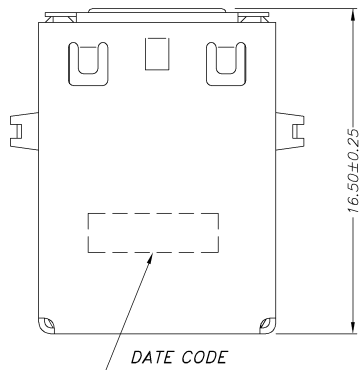
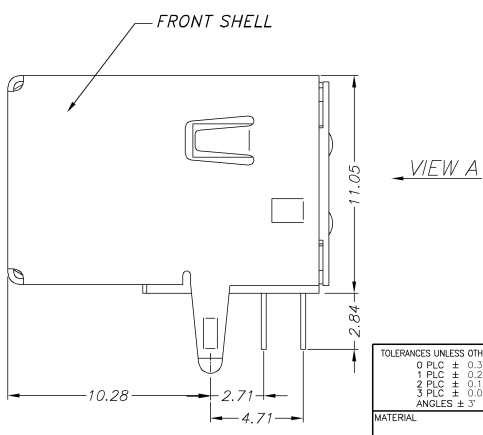
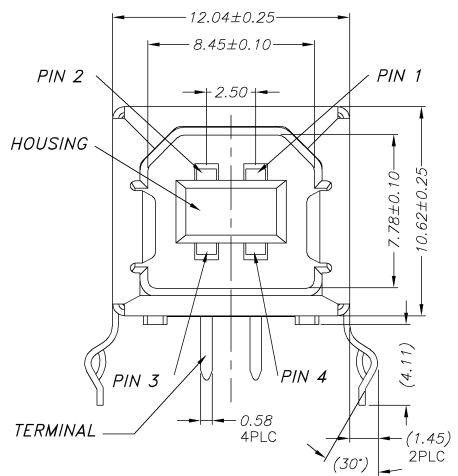

30 μ"	BLACK	1734176-6
	BEIGE	1734176-5
5 μ"	BLACK	1734176-4
	BEIGE	1734176-3
2 μ"	BLACK	1734176-2
	BEIGE	1734176-1
MIN. GOLD THICKNESS	HSG. COLOR	PART NUMBER

⚠️ OBSOLETE

TOLERANCES UNLESS OTHERWISE SPECIFIED:		DWN	O. HU	10-AUG-2007	Tyco Electronics Corporation Taipet, Taiwan
0 PLC ± 0.3 1 PLC ± 0.25 2 PLC ± 0.12 3 PLC ± 0.08 ANGLES ± 3°		CHK	S. HOU	10-AUG-2007	
MATERIAL	SEE NOTE	APVD	W.J. KE	10-AUG-2007	RCPT. ASS'Y, R/A, THRUHOLE USB B TYPE, W/ REAR SHELL
FINISH	SEE NOTE	PRODUCT SPEC	108-57085		
		APPLICATION SPEC			LOC
		WEIGHT			SIZE
					DW
					A ₃
					SCALE
					1 OF 1

O2	REV PER ECO-10-000445	KK	AEG	JAN10
O1	CHANG LOCATION OF DATE CODE	ECR-07-018698	CHK	10AUG 2007
O	FIRST RELEASED	FW00-0074-04	CHK	30APR 2004
LTR	REVISION RECORD	ECN	DWN	CHK
			DATE	

THIS INFORMATION IS CONFIDENTIAL AND IS PRESENTED TO YOU ON THE CONDITION THAT NO FURTHER DISCLOSURE IS MADE BY YOU TO OTHER THAN AMP PERSONNEL WITHOUT THE WRITTEN PERMISSION OF AMP. DIMENSIONS IN MILLIMETERS. DO NOT SCALE PRINT.

PRINT DW

8 7 6 5 4 3 2 1 CUSTOMER DRAWING