

NUMBER C-1775051  
 3RD ANGLE PROJECTION  
 METRIC

NOTE:

- MATERIAL:  
 HOUSING: THERMOPLASTIC HIGH TEMP., UL 94V-0 COLOR: GRAY.  
 CONTACT: PHOSPHOR BRONZE, THICKNESS: 0.25mm.  
 SHIELD: PHOSPHOR BRONZE, THICKNESS: 0.40mm.
- FINISH:  
 CONTACT: 30u" GOLD PLATING ON CONTACT AREA,  
 100u" MIN TIN-Cu PLATED ON SOLDER TAILS  
 50u" MIN NICKEL UNDERPLATED ALL OVER.  
 SHIELD: 100u" MIN HALF-BRIGH TIN PLATED OVER 80u" MIN Cu  
 UNDERPLATED ALL OVER.
- REFLOW SOLDER CAPABLE TO 260°C PER TYCO SPEC 109-201, CONDITION C.
- RoHS 2002/95/EC COMPLIANT
- CHOOSE PRE-FIX FROM LEFT TABLE AND SUFFIX FROM RIGHT TABLE FOR DESIRED PART NUMBER COMBINATION.

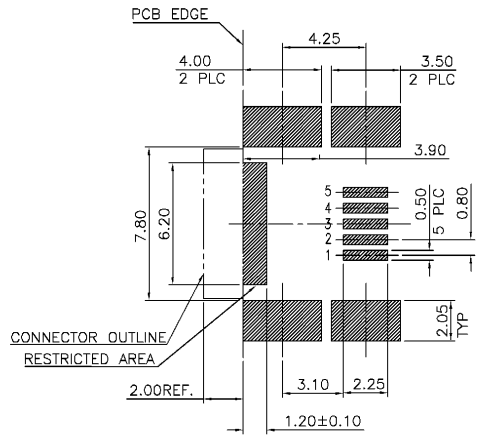
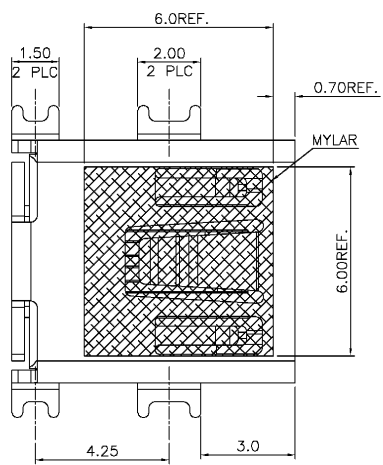

RECOMMENDED PCB LAYOUT (MOUNTING SIDE)  
 (TOP VIEW) (TOLERANCE=±0.05)

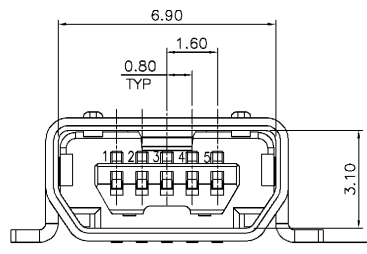
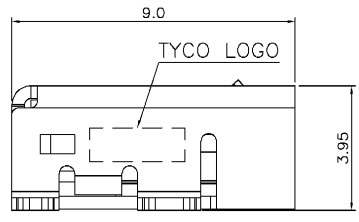
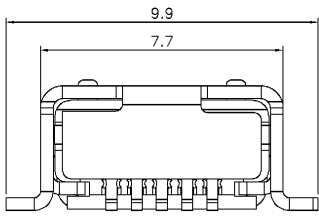

0.10  
 ALL SOLDER TAILS & MOUNT PEGS

THIS INFORMATION IS CONFIDENTIAL AND IS OBSOLETE TO YOU ON CONDITION THAT  
 NO FURTHER DISCLOSURE IS MADE BY YOU TO OTHER THAN AMP PERSONNEL WITHOUT  
 WRITTEN PERMISSION FROM AMP. DIMENSIONS IN MILLIMETERS. DO NOT SCALE PRINT.

PRINT DIST  
 DW

0	FIRST RELEASED	FZ00-0042-05	CH	11MAR 2005
LTR	REVISION RECORD	ECN	DWN	CHK
				DATE

TOLERANCES UNLESS OTHERWISE SPECIFIED: 0 PLC ±0.50 1 PLC ±0.38 2 PLC ±0.25 3 PLC ±0.10 ANGLES ±3°	DWN	O. HU	TYCO HOLDINGS (BERMUDA) VII LTD. TAIWAN BRANCH
	CHK	S. HOU	
MATERIAL	APVD	W.J. KE	NAME
SEE NOTE	PRODUCT SPEC	10-MAR-2005	MINI USB CONN., RCPT, 5 POS, SMT, AB TYPE
FINISH	QUALIFICATION TEST REPORT	501-57637	LOC
SEE NOTE	WEIGHT	10.5 gram	SIZE
			DW
			A3
			SCALE
			1 OF 2
			SHEET
			1 OF 2

8 | 7 | 6 | 5 | 4 | 3 | 2 | 1  
 CUSTOMER DRAWING

D  
 C  
 B  
 A

NUMBER C-1775051  
METRIC  
3RD ANGLE PROJECTION

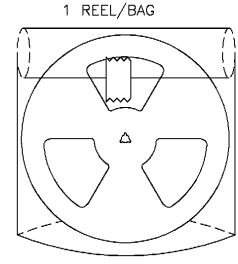
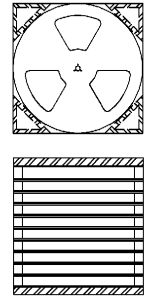
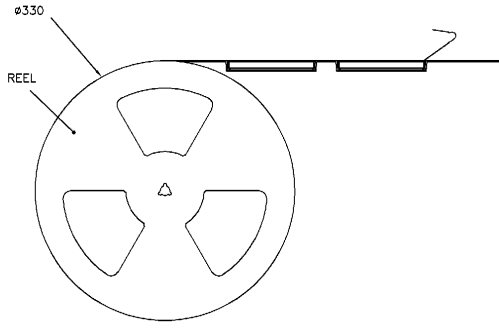

- NOTES :
- MATERIAL :
    - EMBOSSED CARRIER: PS
    - COVER TAPE: PET
    - SHIPPING CARTON: CORRUGATED FIBER.
  - DIMENSION :
    - REEL: W=24 , $\phi$ A=330
    - SHIPPING CARTON: L=349.2,W=147.6, H=156.
  - QUANTITY :
    - PRIMARY PACKING: 700PCS/REEL.
    - SECONDARY PACKING: 10REEL/ CARTON(7000PCS).
  - WEIGHT :
    - NET WEIGHT: 11.5kg/CARTON.
    - GROSS WEIGHT: 10.5kg/CARTON.
    - PEELING RESISTANCE: 10g~130g.
    - PELING SPEED: 300mm/minutes.

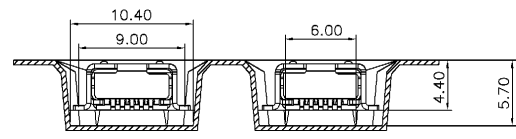
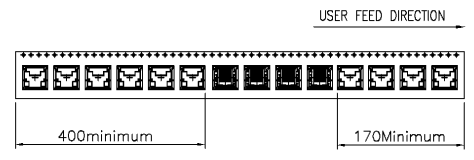
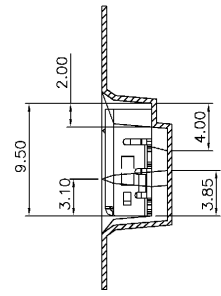
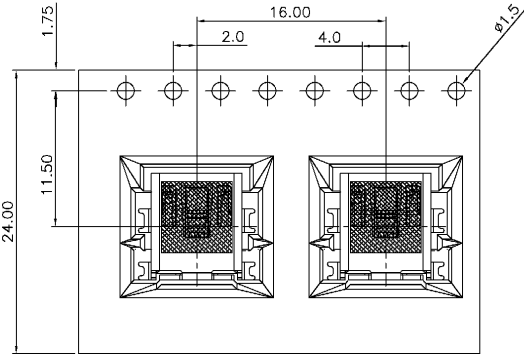
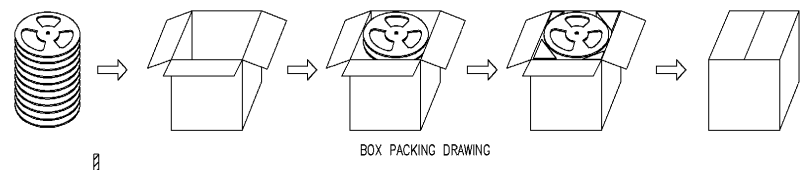

TOLERANCES UNLESS OTHERWISE SPECIFIED:	DWN	O. HU	<b>tyco</b>	TYCO HOLDINGS (BERMUDA)
0 PLC	CHK	10-MAR-2005	<b>Electronics</b>	VII LTD. TAIWAN BRANCH
1 PLC		S. HOU	NAME	
2 PLC		10-MAR-2005		
3 PLC				
ANGLES				
MATERIAL	APVD	W.J. KE	MINI USB CONN., RCPT,	
-		10-MAR-2005	5 POS, SMT, AB TYPE	
FINISH	APPLICATION SPEC		LOC	SIZE
-			DW	A <sub>3</sub>
	WEIGHT		SCALE	DRAWING NO
			--	C-1775051
				REV
				0
				SHEET
				2 OF 2

SEE SHEET 1.				
LTR	REVISION RECORD	ECN	DWN_CHK	DATE

PRINT DW  
THIS INFORMATION IS CONFIDENTIAL AND IS DISCLOSED TO YOU ON CONDITION THAT NO FURTHER DISCLOSURE IS MADE BY YOU TO OTHER THAN A&P PERSONNEL WITHOUT DIMENSION IN MILLIMETERS. DO NOT SCALE PRINT.

8 7 6 5 4 3 2 1  
CUSTOMER DRAWING

D  
C  
B  
A