

NUMBER C-1734517  
METRIC  
3RD ANGLE PROJECTION

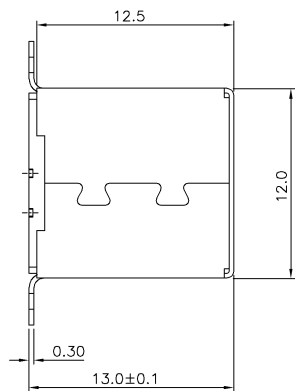

0.10  
ALL SOLDER TAILS AND PEGS

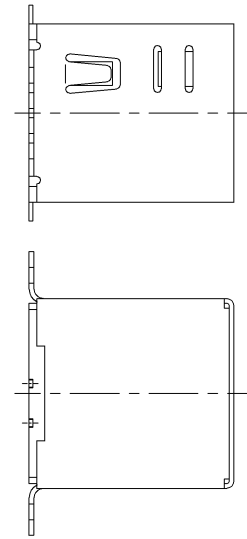

- NOTES :
- MATERIAL:  
HOUSING: THERMOPLASTIC, UL 94V-0, COLOR: BLACK.  
CONTACT: PHOSPHOR BRONZE, THICKNESS=0.25mm.  
SHELL: PHOSPHOR BRONZE, THICKNESS=0.30mm.
  - FINISH:  
CONTACT: GOLD PLATING (SEE TABLE ON CONTACT AREA,  
100u" MIN. TIN-Cu PLATING ON SOLDER TAILS,  
50u" MIN. NICKEL UNDERPLATED OVER ALL.  
SHELL: 100u" MIN. NICKEL PLATED OVER 50u" MIN. Cu UNDERPLATED.
  - REFLOW SOLDER CAPABLE TO 260°C PER TYCO SPEC 109-201, CONDITION B.

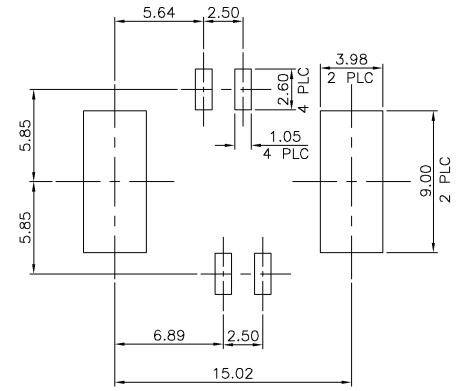
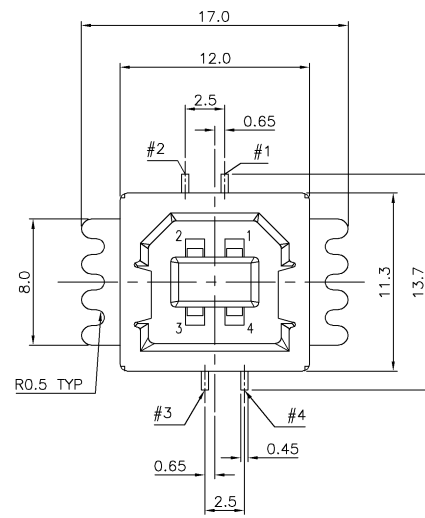

RECOMMENDED PCB LAYOUT  
(TOLERANCE: ±0.05)

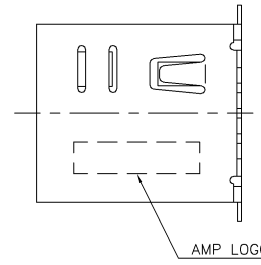

THIS INFORMATION IS CONFIDENTIAL AND IS DISCLOSED TO YOU ON CONDITION THAT NO FURTHER DISCLOSURE IS MADE BY YOU TO OTHER THAN AMP PERSONNEL WITHOUT DIMENSIONS IN MILLIMETERS. DO NOT SCALE PRINT.

PRINT DIST DW

A	FIRST RELEASED			OH	23JUN 2006
LTR	REVISION RECORD		ECN	DWN	CHK DATE

TOLERANCES UNLESS OTHERWISE SPECIFIED:		DWN	O. HU		TYCO HOLDINGS (BERMUDA) VII LTD. TAIWAN BRANCH
0 PLC	±0.38	CHK	22-JUN-2006		
1 PLC	±0.25		S. HOU	NAME USB B TYPE, TOP ENTRY, 4 POSITION, SMT TYPE	
2 PLC	±0.13		22-JUN-2006		
3 PLC	±0.05			LOC SIZE DRAWING NO DW A3 C-1734517 REV A	
ANGLES	±3°				
MATERIAL	SEE NOTE	APVD	W.J. KE	SCALE -- SHEET 1 OF 2	
FINISH	SEE NOTE	PRODUCT SPEC	22-JUN-2006		
		QUALIFICATION TEST REPORT	108-57538		
		WEIGHT	501-57618		

CUSTOMER DRAWING

NUMBER C-1734517

3RD ANGLE PROJECTION

METRIC

THIS INFORMATION IS CONFIDENTIAL AND IS DECIDED TO YOU ON CONDITION THAT NO FURTHER DISCLOSURE IS MADE BY YOU TO OTHER THAN AMP PERSONNEL WITHOUT THE WRITTEN PERMISSION OF AMP. DIMENSIONS IN MILLIMETERS. DO NOT SCALE PRINT.

PRINT DIST DW

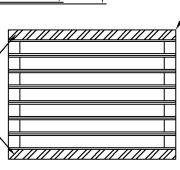
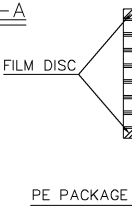
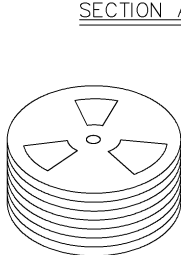
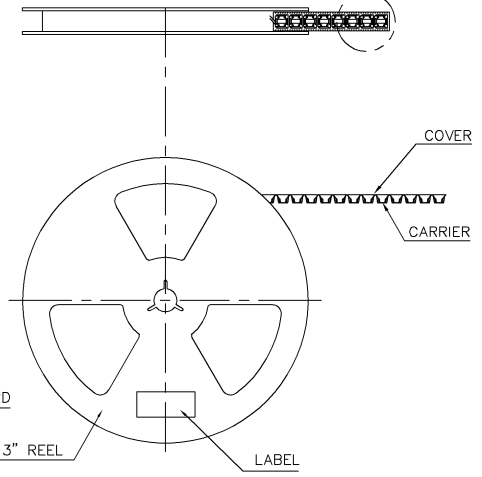
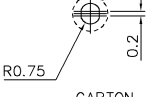
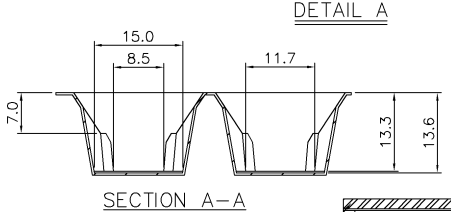
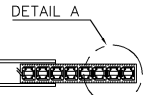
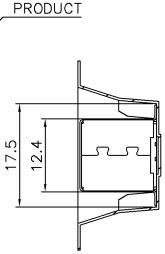
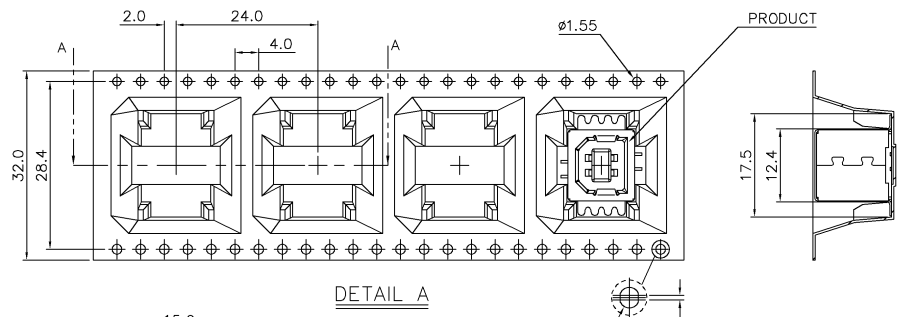

PACKING BOX

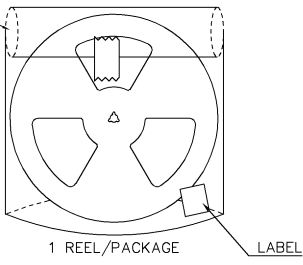
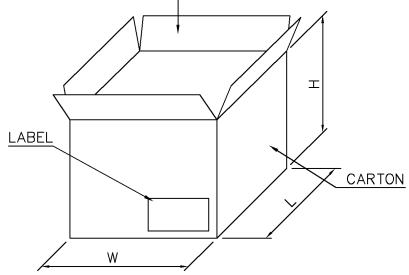
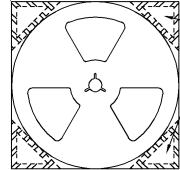

- NOTES :
- MATERIAL :
    - 1.1 EMBOSSED CARRIER: PS.
    - 1.2 COVER: PET.
    - 1.3 CARTON: K=A.
  - DIMENSION :
    - 2.1 REEL: W=32.0.
    - 2.2 CARTON: L=348, W=348, H=340.
  - QUANTITY :
    - 3.1 PRIMARY PACKING: 200PCS/REEL.
    - 3.2 SECONDARY PACKING: 8 REEL/CARTON(1,600PCS).
  - WEIGHT :
    - 4.1 NET WEIGHT: 8.0kg/CARTON.
    - 4.2 GROSS WEIGHT: 9.0kg/CARTON.
  - PEELING RESISTANCE: 10g~130g.

TOLERANCES UNLESS OTHERWISE SPECIFIED:		DWN	O. HU	<b>tyco</b>	TYCO HOLDINGS (BERMUDA)
0	PLC		22-JUN-2006	<b>Electronics</b>	VII LTD. TAIWAN BRANCH
1	PLC	CHK	S. HOU	NAME	
2	PLC		22-JUN-2006		
3	PLC				
	ANGLES				
MATERIAL	APVD	W.J. KE	22-JUN-2006	USB B TYPE, TOP ENTRY, 4 POSITION, SMT TYPE	
SEE NOTE	PRODUCT SPEC				
FINISH	APPLICATION SPEC				
SEE NOTE	WEIGHT				
		LOC	SIZE	DRAWING NO	REV
		DW	A <sub>3</sub>	C-1734517	A
		SCALE	SHEET		
		--	2 OF 2		

SEE SHEET 1.	ECN	DWN/CHK	DATE
LTR	REVISION RECORD		

8 1 7 1 6 1 5 1 4 1 3 1 2 1 1 CUSTOMER DRAWING

D  
C  
B  
A