

THIS IS A C.A.D. GENERATED DRAWING
DO NOT MAKE MANUAL REVISIONS TO MASTER.

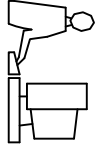

ISSUE NUMBER	8
REMOVE P/N: 690-009-221-013	7
R.STA:MONICA MAY.07/10	7
ADD P/N: 690-009-521-1013 AND 690-009-621-1013	8
R.STA:MONICA JUN.01/10	8
690-009-521-313 WAS	8
690-009-521-1013 AND	9
690-009-621-313 WAS	9
690-009-621-1013. ADD TAPE & REEL AND PCB TOLERANCE	9
R.STA:MONICA JUN.07/10	9

SPECIFICATION:

CONTACT CURRENT RATING: 1.8 A PER PIN MIN. AT25°C (STILL AIR)
 INSULATION RESISTANCE: 100 MEGOHMS MIN. AT DC FOR 1 MINUTE
 DWV: .100 VAC FOR 1 MINUTE
 LOW LEVEL CONTACT RESISTANCE: 50 MILLIONHMS MAX.
 INSERTION FORCE: 3.57 KG.(35N) MAX.
 EXTRACTION FORCE: 1.02 KG.(10N) MIN. FOR INITIAL
 OPERATING TEMPERATURE: -30°C TO +85°C

MATERIALS:

SHELL: BRASS, NICKEL PLATED
 CONTACTS: PHOSPHOR BRONZE, PLATED WITH 15 MICRONS OF GOLD
 ON CONTACT AREA, TIN ON TAIL OVER NICKEL.
 INSULATORS: PBT, UL94V-0, BLUE COLOR (PANTONE 300C)

PART NUMBERS	GOLD PLATING	PACKAGING DETAIL
690-009-521-013	15 u" OF GOLD	TAPE AND REEL
690-009-521-313	15 u" OF GOLD	PLASTIC TRAY
690-009-621-013	30 u" OF GOLD	TAPE AND REEL
690-009-621-313	30 u" OF GOLD	PLASTIC TRAY

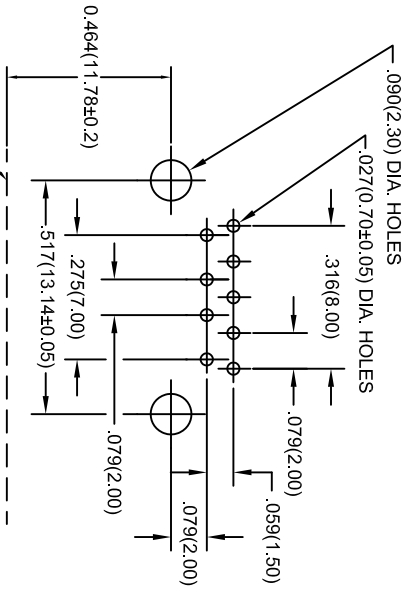
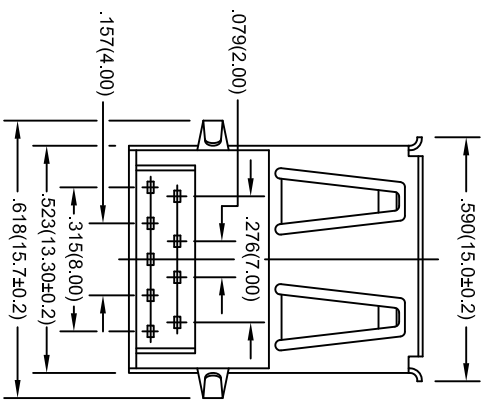

PC BOARD MOUNTING DIMENSIONS



THIS SERIES FULLY CONFORMS TO THE
 EUROPEAN UNION DIRECTIVES 2002/95/EC
 AND 2002/96/EC FOR ROHS COMPLIANCY.

NOTE:

TOLERANCE FOR ALL DIMENSIONS IN MM IS ± 0.1 ,
 UNLESS OTHERWISE SPECIFIED

USB-A RECEPTACLE 90° DIP, 3.0 VERSION

ACAD REFERENCE NO.	690-009-521-013
DRAWN: F.BRIONES	DATE: AUG.17/09
PART NUMBER	SEE ABOVE
DRAWING NUMBER	690-009-521-013
SHEET 1 OF 3	ISSUE 9

EDAC INC
 TORONTO, ONTARIO
 CANADA
 YOUR CONNECTION TO QUALITY & SERVICE

THESE DRAWINGS AND SPECIFICATIONS
 ARE THE PROPERTY OF EDAC INC. AND
 SHALL NOT BE REPRODUCED OR COPIED
 OR USED AS THE BASIS FOR THE
 MANUFACTURE OR SALE OF APPARATUS
 WITHOUT WRITTEN PERMISSION.

THIS IS A C.A.D. GENERATED DRAWING
DO NOT MAKE MANUAL REVISIONS TO MASTER.

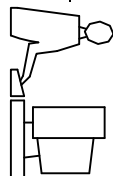

ISSUE NUMBER
SEE PAGE 1 OF 3
(9)

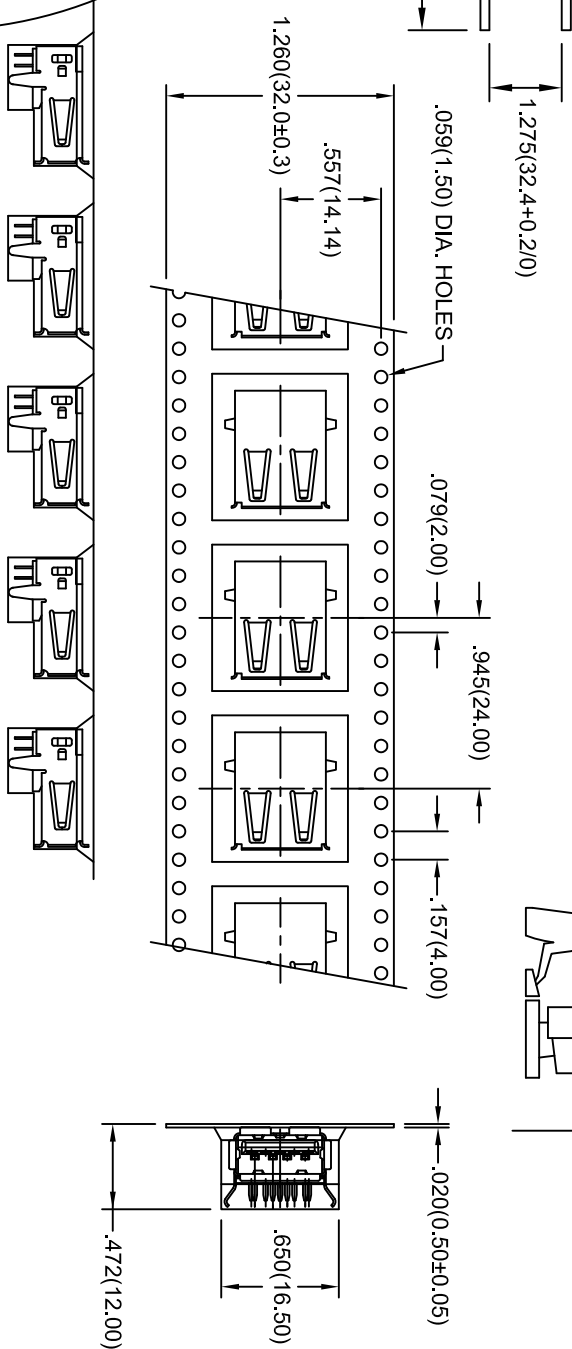
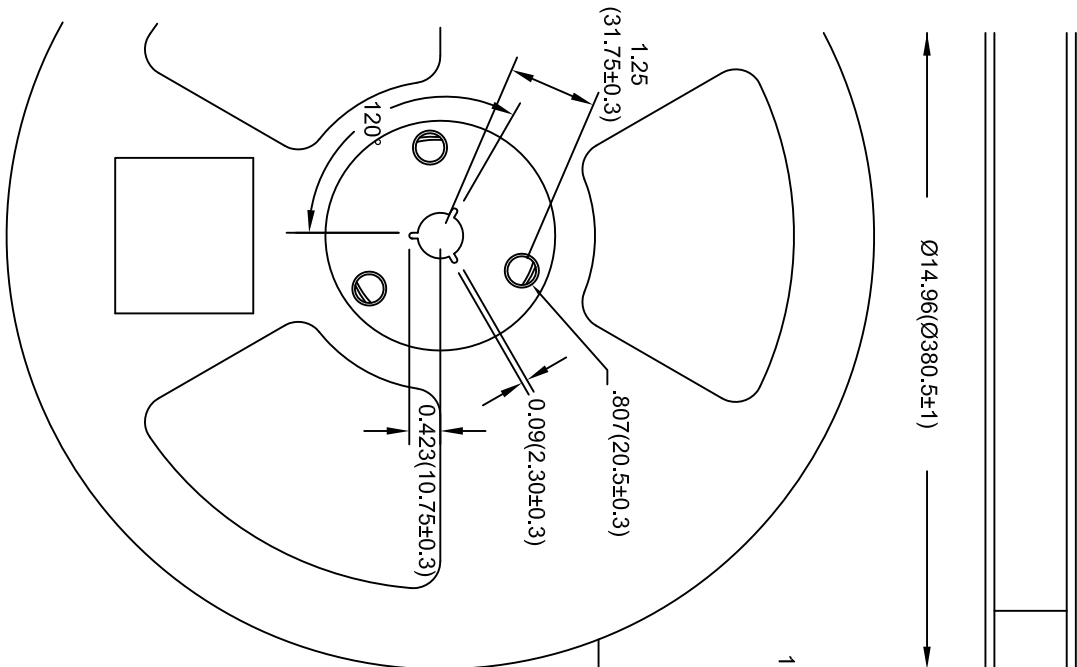

NOTE:
TOLERANCE FOR ALL DIMENSIONS IN MM IS ±0.1, UNLESS OTHERWISE SPECIFIED

**USB-A RECEPTACLE 90° DIP, 3.0 VERSION
PACKAGING REEL (350 PCS PER REEL)**

EDAC INC
TORONTO, ONTARIO
CANADA
YOUR CONNECTION TO QUALITY & SERVICE

THESE DRAWINGS AND SPECIFICATIONS
ARE THE PROPERTY OF EDAC INC. AND
SHALL NOT BE REPRODUCED OR COPIED
OR USED AS THE BASIS FOR THE
MANUFACTURE OR SALE OF APPARATUS
WITHOUT WRITTEN PERMISSION.

ACAD REFERENCE NO.	690-009-521-013
DRAWN: F. BRIONES	DATE: AUG. 17/09
PART NUMBER	SEE PAGE 1 OF 3
DRAWING NUMBER	690-009-521-013
	SHEET 2 OF 3
	ISSUE
	9

THIS IS A C.A.D. GENERATED DRAWING
DO NOT MAKE MANUAL REVISIONS TO MASTER.

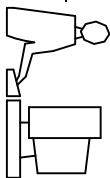

ISSUE NUMBER
SEE PAGE 1 OF 3

9

11.023 [280.0]

0.401 [10.2]

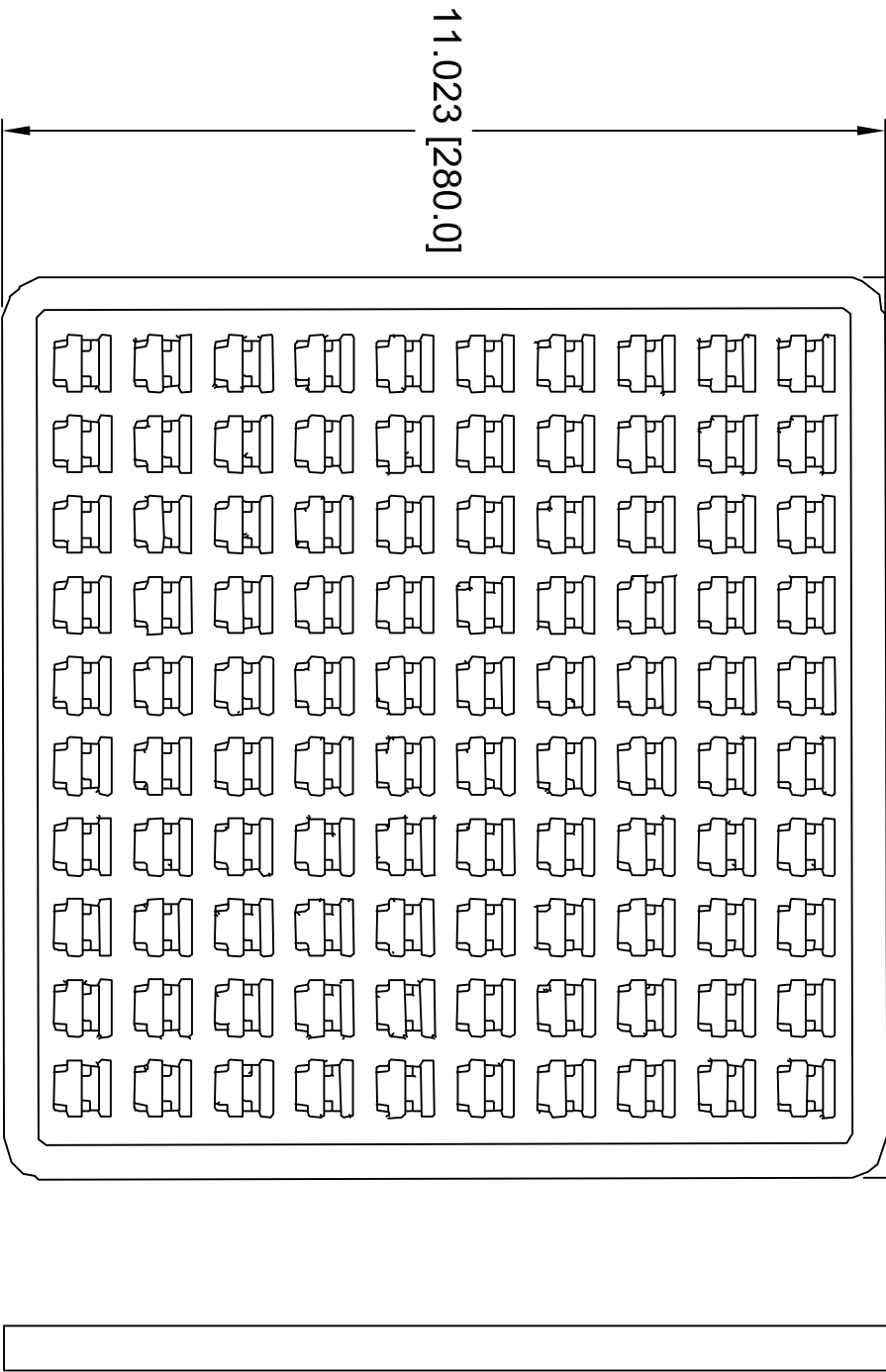

NOTES:

1. MATERIAL: TRANSPARENT PVC
2. THICKNESS: 0.20 ± 0.05MM
3. PCS / TRAY : 100PCS
4. TRAY / BOX : 25TRAYS
5. PCS / BOX : 2500PCS
6. CARTON SIZE:
300MM x 300MM x 265MM

USB-A RECEPTACLE 90° DIP, 3.0 VERSION
TRAY PACKAGING (100 PCS PER TRAY)

EDAC INC
TORONTO, ONTARIO
CANADA
YOUR CONNECTION TO QUALITY & SERVICE

THESE DRAWINGS AND SPECIFICATIONS
ARE THE PROPERTY OF EDAC INC. AND
SHALL NOT BE REPRODUCED OR COPIED
OR USED AS THE BASIS FOR THE
MANUFACTURE OR SALE OF APPARATUS
WITHOUT WRITTEN PERMISSION.

ACAD REFERENCE NO. 690-009-521-013

DRAWN: R. STAMONICA DATE: JUN.01/10

PART NUMBER

SEE PAGE 1 OF 3

SHEET 3 OF 3

DRAWING NUMBER

690-009-521-013

ISSUE

9