

Wire to Board Terminals (AMP-IN Terminal)

Material and Finish

Tin-plated
Brass or phosphor bronze

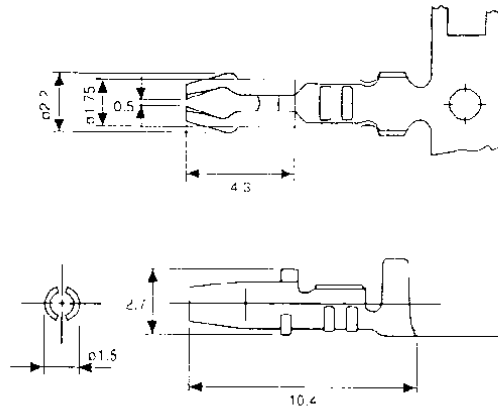

Part Number: 170072-1
Application Spec: 114-5028
Product Specifications:108-5012
Recommended PCB Hole Size:
Ø1.8-Ø1.9mm

AWG	Wire Size	Wire Insulation
	mm ²	Diameter
24-20	0.20-0.56	1.52-2.79

Material and Finish

Tin-plated brass

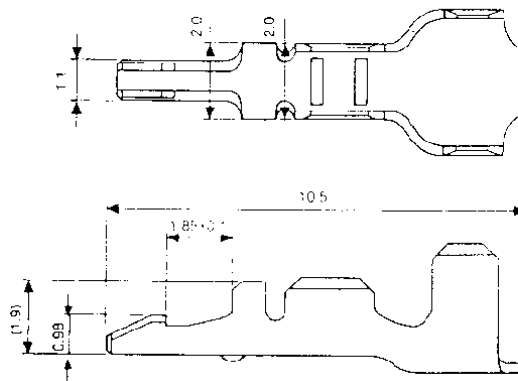

Part Number: 170197-1 (with dimple) and 170197-2 (without dimple)
Application Spec: 114-5014
Product Specifications:108-5012
Recommended PCB Hole Size:
Ø1.2-Ø1.6mm

AWG	Wire Size	Wire Insulation
	mm ²	Diameter
24-20	0.20-0.56	1.6-2.3

AMP VASE Terminal

Material and Finish

Tin-plated brass

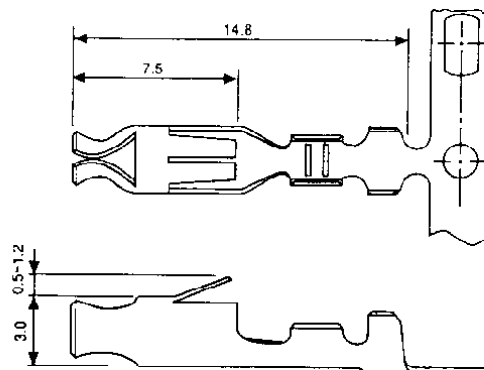

Part Number: 170219-1 and 170219-2 (Low mating force)
Application Spec: 114-5016
Product Specifications:108-5012
Mates with 1.57 diameter pin

AWG	Wire Size	Wire Insulation
	mm ²	Diameter
24-20	0.20-0.53	1.2-2.6