

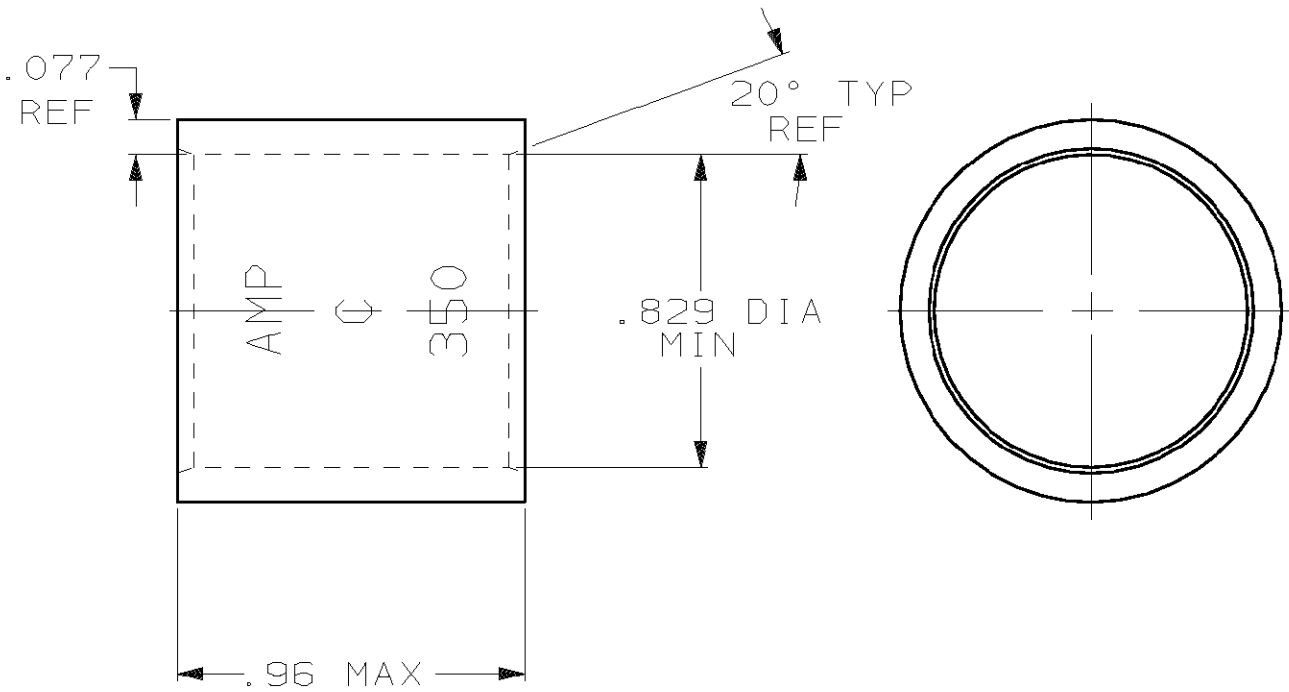

LOC G	DIST 36	P	F	REVISIONS			
				LTR	DESCRIPTION	DATE	APPROVED
				E	REV PER 0G3A-0637-01	030CT02	JR/MS

- ① CLEANED, UNPLATED
- ② PREPRODUCTION - FASR REQ.



THIS DRAWING IS UNPUBLISHED. BY AMP INCORPORATED. ALL INTERNATIONAL RIGHTS RESERVED. © COPYRIGHT 19

	①	② 1-324449-0
325-375 MCM	TIN PL PER ASTM B 545 .000150 MIN THK	324449
RANGE	FINISH	PART NO

DO NOT SCALE PRINT. UNLESS SPECIFIED DIMENSIONS IN INCHES TOLERANCES ON: 2 PLC DEC ± - 3 PLC DEC ± - ANGLES ± -	DR 1/16/89 P FORTNEY	AMP INCORPORATED Harrisburg, Pa. 17105	
	CHK 6/20/89 MS FEHER		
MATERIAL COPPER ASTM-B-75 ANNEALED	APPD 6/20/89 WJ VOCKROTH	NAME WIRE SPLICE, PARALLEL, AMPOWER, WIRE SIZE: 350 MCM	
	APPD 6/20/89 R ADAMS	SIZE <b>A</b>	FSCM NO 00779
FINISH SEE TABLE	PRODUCT SPEC -	DRAWING NO 324449	SCALE 2:1
	APPLICATION SPEC -	WEIGHT .068 LB.	SHEET 1 OF 1

