

4 3 2 1
 DRAWING MADE IN THIRD ANGLE PROJECTION
 THIS DRAWING IS UNPUBLISHED. RELEASED FOR PUBLICATION
 © COPYRIGHT 19 BY AMP INCORPORATED. ALL INTERNATIONAL RIGHTS RESERVED.

LOC	DIST	P	F	ZONE	LTR	REVISIONS	DATE	APPD
G	14				B	REVISED PER 0720-0937-96	05JUN96	gms

METRIC
 DIMENSIONS LISTED IN mm [INCHES]

AMP WIRE RANGE	UL E13288 Listed
12-10 AWG STRANDED	12-10 AWG STRANDED
CS LR7189 Certified	MILITARY P/N AND CLASS
NOT CERTIFIED	NOT APPLICABLE

⚠ STAMP AMP 12-10* APPROX AS SHOWN
 ⚠ MAXIMUM LENGTH DOES NOT INCLUDE
 MANUFACTURING TABS

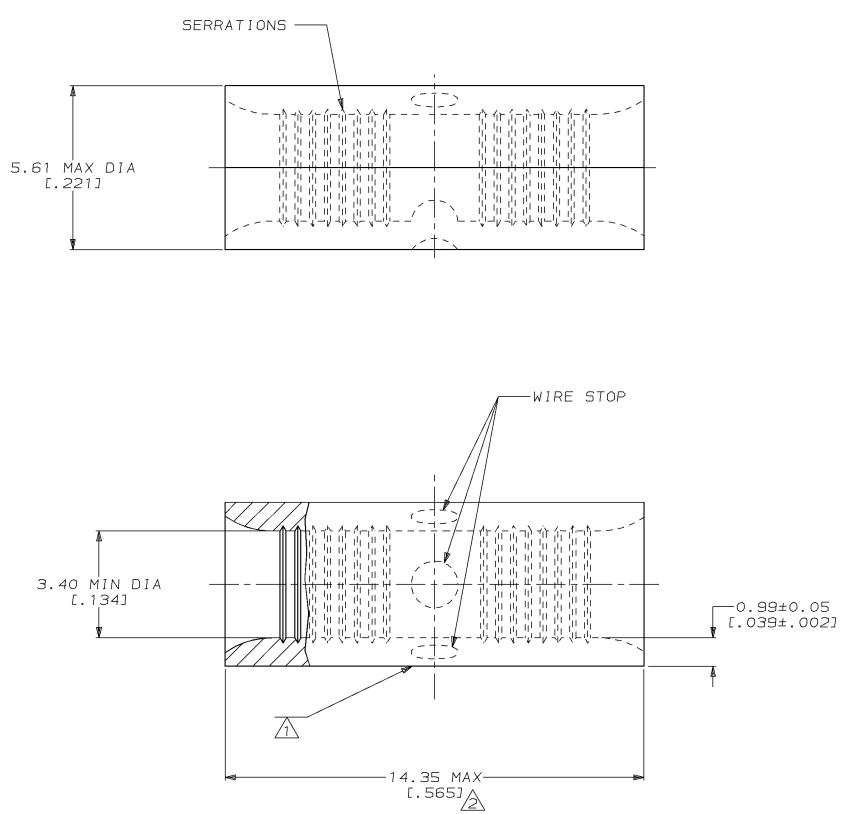

50	LOOSE PIECE, BOX	8-34228-2
-	LOOSE PIECE	34228

AMP INCORPORATED
CUSTOMER SERVICE SYSTEMS

FOR ADDITIONAL
 PRODUCT INFORMATION OR
 COPIES OF DRAWINGS
 AND TECHNICAL DOCUMENTS

PRODUCT INFORMATION CENTER
 1-800-522-6752

FOR APPLICATION
 TOOLING INFORMATION

TOOLING ASSISTANCE CENTER
 1-800-722-1111

FOR ORDER ENTRY

1-800-526-5142

MAX RECOMMENDED OPERATING
 TEMPERATURE:
 170°C MAX

VOLTAGE RATING:
 NOT APPLICABLE

WIRE CROSS SECTIONAL AREA RANGE:
 2.62-5.64mm² [5, 180-13, 100] CIR MILS
 STRANDED

THIS DRAWING IS A CONTROLLED DOCUMENT FOR
 AMP INCORPORATED. IT IS SUBJECT TO CHANGE
 AND THE CONTROLLING ENGINEERING ORGANIZATION
 SHOULD BE CONTACTED FOR THE LATEST REVISION.

DO NOT SCALE PRINT.
 UNLESS SPECIFIED
 DIMENSIONS IN mm [INCHES]
 TOLERANCES ON :
 2 PLC DEC ± -
 3 PLC DEC ± -
 ANGLES ± -

MATERIAL
 COPPER PER
 ASTM B-152
 ANNEALED

FINISH
 TIN PLATE
 0.00254 [0.000100] MIN
 THK PER MIL-T-10727

DR 3-1-93
 TA BRYNKMAN

CHK 3-1-93
 DA PATTERSON

APPD 3-1-93
 DE MILLER

APPD 3-1-93
 JL MECKLEY

PRODUCT SPEC
 -

APPLICATION SPEC
 -

WEIGHT
 -

AMP AMP Incorporated
 Harrisburg, PA 17105-3608

NAME
**SPLICE, BUTT,
 STANDARD, BUDGET**

SIZE
 C 00779

DRAWING NO
 C-34228

SCALE
 10:1

SHEET
 1 OF 1