

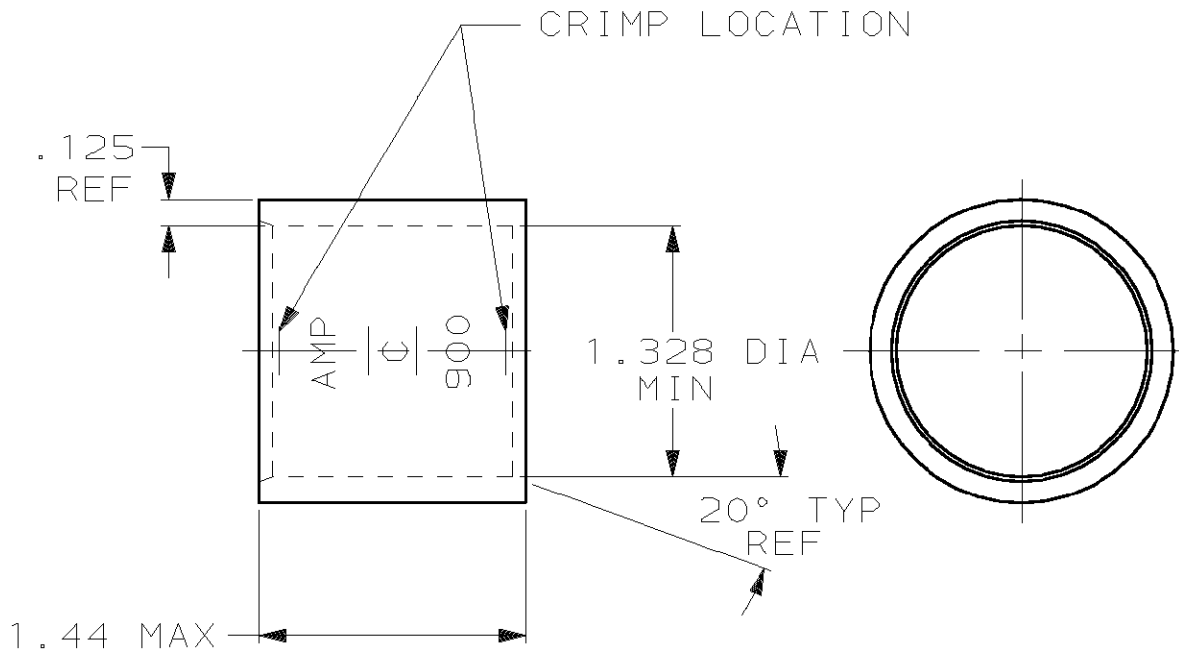

LOC G	DIST 86	P	F	REVISIONS		
			LTR	DESCRIPTION	DATE	APPROVED
			F	REV PER 0G3A-0637-01	030CT02	JR/MS

1 PREPRODUCTION - FASR REQ



THIS DRAWING IS UNPUBLISHED. BY AMP INCORPORATED. ALL INTERNATIONAL RIGHTS RESERVED. © COPYRIGHT 19

850-950 MCM	CLEANED, UNPLATED	1-324455-0
	TIN PL PER ASTM B545 .000150 MIN THK	324455
RANGE	FINISH	PART NO

DO NOT SCALE PRINT. UNLESS SPECIFIED DIMENSIONS IN INCHES TOLERANCES ON:  
 2 PLC DEC ± -  
 3 PLC DEC ± -  
 ANGLES ± -

MATERIAL  
 COPPER  
 ASTM-B-75  
 ANNEALED

FINISH  
 SEE TABLE

DR 1/16/89  
 P FORTNEY

CHK 6/20/89  
 MS FEHER

APPD 6/20/89  
 WJ VOCKROTH

APPD 6/20/89  
 R ADAMS

PRODUCT SPEC  
 -

APPLICATION SPEC  
 -

WEIGHT .263 LB.

**AMP** | AMP INCORPORATED  
 Harrisburg, Pa. 17105

NAME  
 WIRE SPLICE, PARALLEL,  
 AMPPOWER, WIRE SIZE: 900 MCM

SIZE <b>A</b>	FSCM NO 00779	DRAWING NO 324455
SCALE 1:1	SHEET 1 OF 1	

