

DRAWING MADE IN THIRD ANGLE PROJECTION  
 THIS DRAWING IS UNPUBLISHED. RELEASED FOR PUBLICATION  
 © COPYRIGHT 19 BY AMP INCORPORATED. ALL INTERNATIONAL RIGHTS RESERVED.

LOC	DIST	P	F	ZONE	LTR	REVISIONS	DESCRIPTION	DATE	APPD
G	14					C	REV & REDRAWN PER 0720-0061-93	4-19-93	APPD

**METRIC**  
 DIMENSIONS LISTED IN mm [ INCHES ]

<b>AMP</b> WIRE RANGE	E13288 Listed
12-10 AWG SOLID OR STRANDED	NOT APPLICABLE
LR7189 Certified	MILITARY P/N AND CLASS
NOT APPLICABLE	NOT APPLICABLE

STAMP AMP 12-10\* APPROX AS SHOWN  
 MAXIMUM LENGTH DOES NOT INCLUDE  
 MANUFACTURING TABS

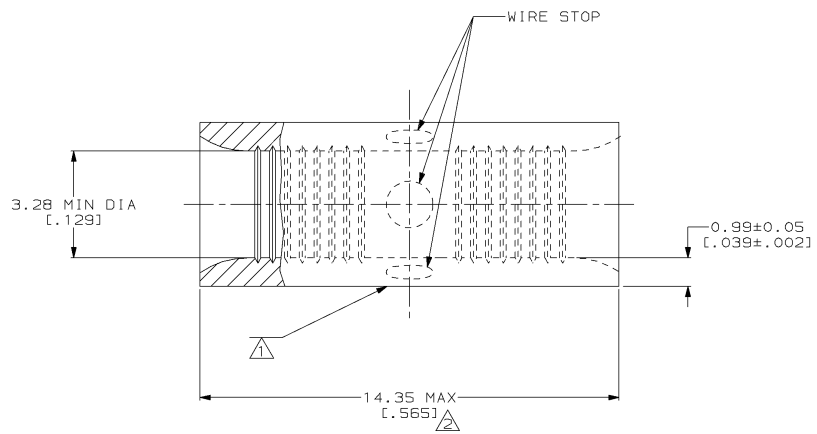
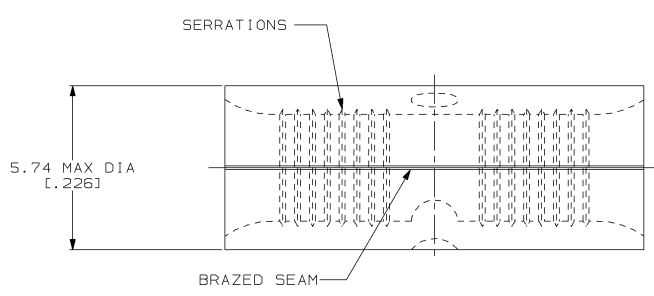

**AMP INCORPORATED**  
**CUSTOMER SERVICE SYSTEMS**

FOR ADDITIONAL  
 PRODUCT INFORMATION OR  
 COPIES OF DRAWINGS  
 AND TECHNICAL DOCUMENTS

PRODUCT INFORMATION CENTER  
 1-800-522-6752

FOR APPLICATION  
 TOOLING INFORMATION

TOOLING ASSISTANCE CENTER  
 1-800-722-1111

FOR ORDER ENTRY

1-800-526-5142

MAX RECOMMENDED OPERATING  
 TEMPERATURE:  
 343°C MAX

VOLTAGE RATING:  
 NOT APPLICABLE

WIRE CROSS SECTIONAL AREA RANGE:  
 2.62-6.64mm<sup>2</sup> [5,180-13,100] CIR MILS  
 SOLID OR STRANDED

THIS DRAWING IS A CONTROLLED DOCUMENT FOR  
 AMP INCORPORATED. IT IS SUBJECT TO CHANGE  
 AND THE CONTROLLING ENGINEERING ORGANIZATION  
 SHOULD BE CONTACTED FOR THE LATEST REVISION.

DO NOT SCALE PRINT.  
 UNLESS SPECIFIED  
 DIMENSIONS IN mm [INCHES]  
 TOLERANCES ON  
 2 PLC DEC ± -  
 3 PLC DEC ± -  
 ANGLES ± -

MATERIAL  
 COPPER PER  
 ASTM B-152  
 ANNEALED

FINISH  
 NICKEL PLATE  
 0.00762 [0.000300] MIN  
 THK PER QQ-N-290

DR 4-19-93  
 TA BRINKMAN

CHK 4-19-93  
 DA PATTERSON

APPD 4-19-93  
 DE MILLER

APPD 4-19-93  
 JL MECKLEY

PRODUCT SPEC  
 -

APPLICATION SPEC  
 -

WEIGHT  
 -

323755  
 PART NO

**AMP** AMP Incorporated  
 Harrisburg, PA 17105-3608

NAME  
**SPLICE, BUTT, STANDARD,  
 HEAT RESISTANT,  
 STRATO-THERM™**

SIZE 00779 DRAWING NO  
**©-323755**

SCALE 10:1 SHEET 1 OF 1