

10	9	8	7	6	5	4	3	2	1		
MATERIAL NO. LOOSE PIECE	ENGINEERING NO. LOOSE PIECE	MATERIAL NO. ON TAPE	ENGINEERING NO. ON TAPE	WIRE SIZE	INSULATOR COLOR	ID MINIMUM	L MAXIMUM	P (A1) MINIMUM	D ±.01/0.25	MWID	B MAX (A1)
192120003	WP-2218X	192120004	WP-2218XT	22-18 AWG	RED	.055/1.40	.93/23.6	.35/8.9	.078/1.98	.145/3.68	.41/10.4
192120005	WP-2614X	192120006	WP-2614XT	16-14 AWG	BLUE	.081/2.06 (A1)	.93/23.6	.35/8.9	.078/1.98	.175/4.44	.41/10.4
192120001	WP-2210X	192120002	WP-2210XT	12-10 AWG	YELLOW	.126/3.20	1.12/28.4	.41/10.4	.107/2.72	.250/6.35	.56/14.2

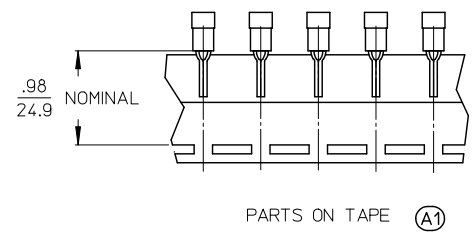
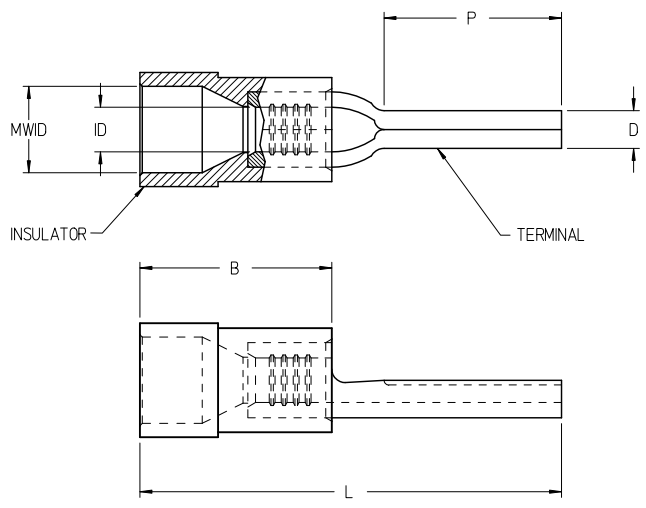

- NOTES:
1. TERMINAL MATERIAL: COPPER
 2. TERMINAL FINISH: TIN PLATED
 3. INSULATOR MATERIAL: PVC
 4. MWID = MAXIMUM WIRE INSULATION DIAMETER.
 5. PARTS ARE ROHS COMPLIANT.

CORRECT TOLERANCES EC NO: WNA2009-0437 DRW:ETHRODAHL 2010/02/19 CHKD:JMACNEIL 2010/03/01 APPR:JMACNEIL 2010/03/18 A1	QUALITY SYMBOLS ▽=0 ▽=0	GENERAL TOLERANCES (UNLESS SPECIFIED)		DIMENSION STYLE IN/MM	SCALE 5:1	DESIGN UNITS INCH	THIRD ANGLE PROJECTION	
		4 PLACES ± --- ± ---	mm INCH	DRAWN BY EMF	DATE 1992/10/08	TITLE WIRE PIN TERMINAL, INSULKRIMP MOLEX INCORPORATED DOCUMENT NO. SD-19212-001 SHEET NO. 1 OF 1		
		3 PLACES ± --- ± ---		CHECKED BY JM	DATE 1992/10/08			
		2 PLACES ± --- ± ---		APPROVED BY JMACNEIL	DATE 2010/03/18			
1 PLACE ± --- ± ---		MATERIAL NO. SEE CHART SIZE B						
DRAFT WHERE APPLICABLE MUST REMAIN WITHIN DIMENSIONS		THIS DRAWING CONTAINS INFORMATION THAT IS PROPRIETARY TO MOLEX INCORPORATED AND SHOULD NOT BE USED WITHOUT WRITTEN PERMISSION						