

MATERIAL NO. LOOSE PIECE	ENGINEERING NO. LOOSE PIECE	MATERIAL NO. TAPE MOUNTED	ENGINEERING NO. TAPE MOUNTED	AWG	"I.D." MIN	"B" MIN	"L" MAX	"P" MIN	"D" ± $\frac{.01}{0.3}$
192110003	WP-1218	192110004	WP-1218 T	22-18	.054/1.37 (G2)	.165/ 4.19	.68/ 17.3	.35/ 8.9	.078/ 1.98
192110005	WP-1614	192110006	WP-1614 T	16-14	.081/2.06	.165/ 4.19	.68/ 17.3	.35/ 8.9	.078/ 1.98
192110001	WP-1210	192110002	WP-1210 T	12-10	.128/3.25	.230/ 5.84	.82/ 20.8	.41/ 10.4	.107/ 2.72

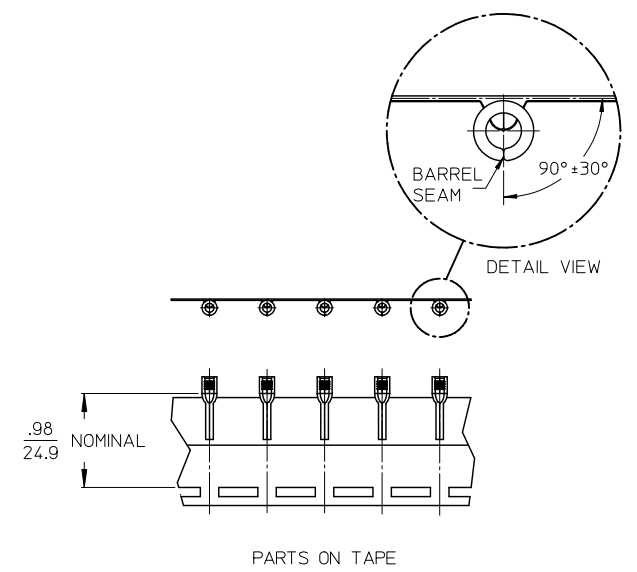
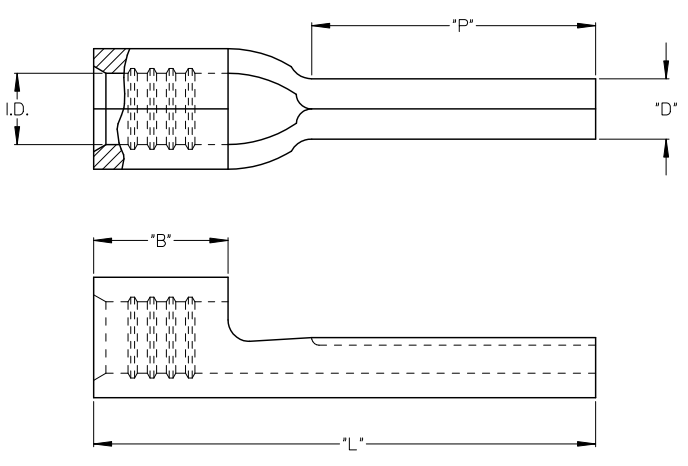

SALES DRAWING

- NOTES:
1. MATERIAL: COPPER
 2. FINISH: ELECTRO-TIN PLATING
 3. PARTS ARE ROHS COMPLIANT.

ID TOLERANCE 22-18 EC NO: DRW:ETHRODAHL 2010/11/17 CHKD: JMCNEIL 2010/11/17 APPR: G2	QUALITY SYMBOLS ▽=0 ▽=0	GENERAL TOLERANCES (UNLESS SPECIFIED)		DIMENSION STYLE IN/MM		SCALE	DESIGN UNITS	THIRD ANGLE PROJECTION		
		mm	INCH	DRAWN BY	DATE	TITLE	INCH	KRIPTITE WIRE PIN TERMINALS 22-18, 16-14, 12-10 AWG MOLEX INCORPORATED		
		4 PLACES ± --- ± ---	3 PLACES ± --- ± ---	B. ENDERLE	02/14/02					
		2 PLACES ± --- ± ---	1 PLACE ± --- ± ---	CHECKED BY DATE H. BIETZEL 02/14/02		APPROVED BY DATE JMCNEIL 2010/03/18		MOLEX INCORPORATED		SHEET NO. 1 OF 1
ANGULAR ± ---°		DRAFT WHERE APPLICABLE MUST REMAIN WITHIN DIMENSIONS		MATERIAL NO. SEE CHART		DOCUMENT NO. SD-19211-002		THIS DRAWING CONTAINS INFORMATION THAT IS PROPRIETARY TO MOLEX INCORPORATED AND SHOULD NOT BE USED WITHOUT WRITTEN PERMISSION		

lb_frame_B_P_ME_1
Rev. D 2004/04/02