

DO NOT SCALE
DIMENSIONS IN mm

METRIC

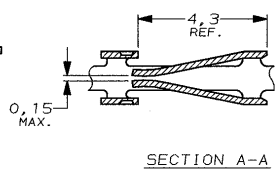
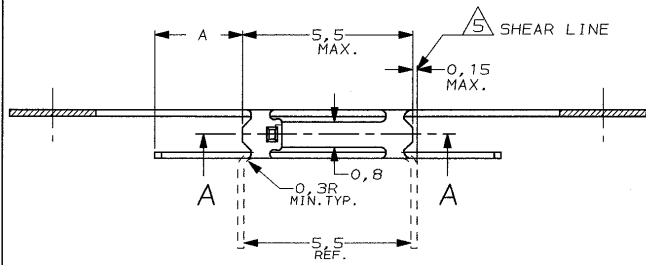

NOTES:

- 1 MATERIAL: PHOSPHORBRONZE.
- 2 CONTACTZONE 0,8µm GOLD OVER 1,25 NICKEL. OVER ENTIRE CONTACT.
- 3 SOLDER TINES 2,0 µm TIN/LEAD.
- 4 SHEAR LINES DEFINE LOOSE PIECE PART.
- 5 TERMINALS REELED FOR AMP MODU MINI-APPLICATOR.
- 6 POINT OF MEASUREMENT FOR PLATING THICKNESS (INSIDE CONTACT BEAMS)

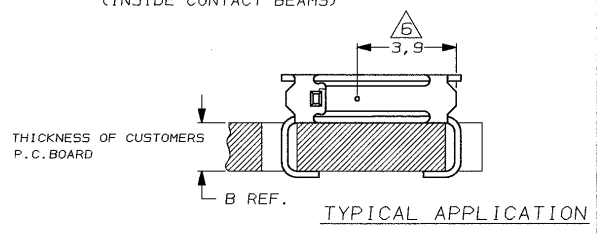
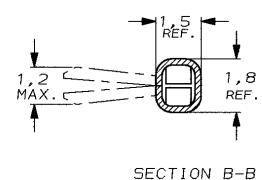
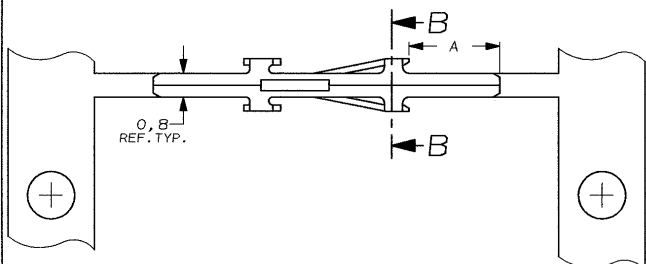

- 7 90° BENDED TYNES FOR LOOSE PIECE VERSIONS ONLY.
- 8 BENDING OF TYNES OF STRIP VERSIONS WILL TAKE PLACE IN APPLICATION TOOL.

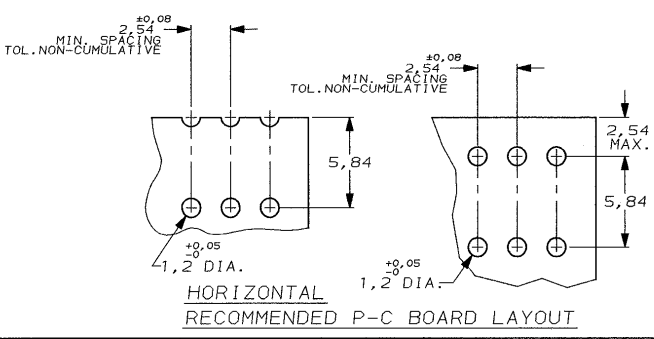

-	-		-	-
1,6	2,9	2, 3	141579-2	141579-4
1,6	2,9	2	141579-1	-
B	A	FINISH	PARTNUMBER STRIP	PARTNUMBER L.P.

CUSTOMER DRAWING		AMP		AMP-HOLLAND B.V. 's-Hertogenbosch, The Netherlands.	
FOR REFERENCE ONLY WILL NOT BE UPDATED		THIS DRAWING IS UNPUBLISHED © COPYRIGHT 19- BY AMP-HOLLAND B.V. ALL INTERNATIONAL RIGHTS RESERVED. AMP PRODUCTS MAY BE COVERED BY U.S. AND FOREIGN PATENTS AND/OR PATENTS PENDING.			
DR. P. BEIJNON	DATE 10-12-90	WIRE RANGE -	NAME -	REV. DATE D M Y	
CHK. R. ANNOKKEE	DATE -	INSUL. RANGE -	CONTACT, RECEPTACLE, MOD II, TYPE C	06 11 00	
APP. L. V. SOEST	DATE -	SIZE A3	SHEET 1 OF 1	DWG. No. 141579	REV. LTR. B

8 | 7 | 6 | 5 | 4 | 3 | 2 | 1