

THIS COPY IS PROVIDED ON A RESTRICTED BASIS AND IS NOT TO BE USED IN ANY WAY DETRIMENTAL TO THE INTERESTS OF PANDUIT CORP.

PANDUIT PART NUMBER		STUD SIZE	DIMENSIONS in.				
PREFIX	PK		A	W	C	M	H
PV18-6FX	-C -M -MY	#6	.88 (22.35)	.30 (7.62)	.21 (5.33)	.69 (17.53)	.15 (3.81)
PV18-8FX	-C -M -MY	#8	.95 (24.13)	.32 (8.13)	.25 (6.35)	.73 (18.54)	.17 (4.32)
PV18-10FX	-C -M -MY	#10	.97 (24.64)	.35 (8.89)	.25 (6.35)	.75 (19.05)	.20 (5.08)

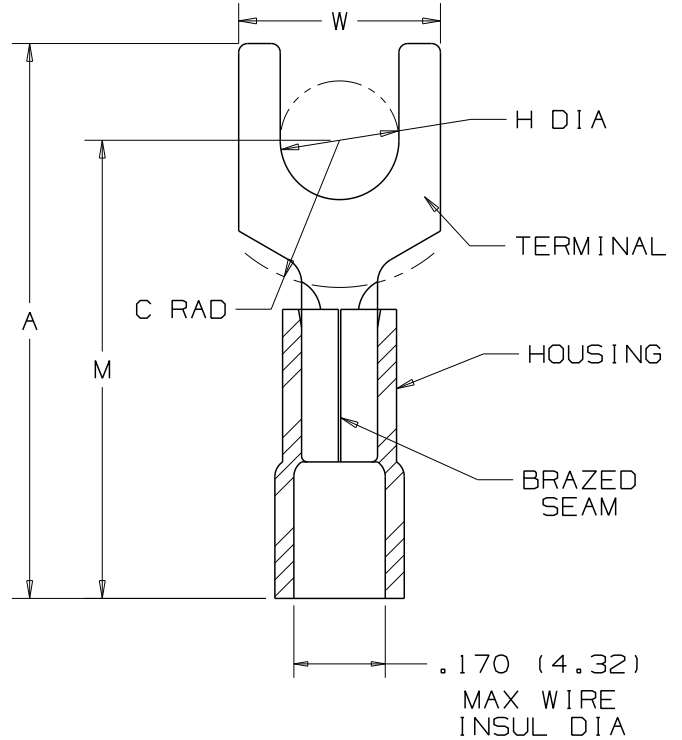

NOTES :

- UL LISTED AND CSA CERTIFIED FOR:
  - 600 V MAX. VOLTAGE RATING
  - 221°F (105°C) MAX. TEMP. RATING
  - #22-18 AWG SOLID OR STRANDED, COPPER WIRE
- PACKAGE QTY.: STD C=100  
BULK M=1000, MY=1000
- MATERIAL:
  - STAMPING - .032 (.81) THK COPPER, TIN PLATED
  - HOUSING - RED VINYL
- WIRE STRIP LENGTH:  $5/16 \begin{matrix} +1/32 \\ -00 \end{matrix} (7.94 \begin{matrix} +.80 \\ -.00 \end{matrix})$
- DIMENSIONS IN BRACKETS ARE IN MILLIMETERS
- INSTALLATION TOOLS:
  - UL AND CSA APPROVED: CT-100, CT-500\*, CT-550\*
  - PANDUIT APPROVED: CT-160, CT-260
  - \* APPROVED FOR EXPANDED WIRE RANGE #22-16 AWG



LISTED  
587H  
E52164



CERTIFIED  
LR31212

**PANDUIT** CORP.

TINLEY PARK, ILLINOIS

Changed "A" dimensions .88 was .83, .95 was .89, .97 was .91  
Removed tolerances from A,W,C,M,H dimensions

#22-18 BARREL VINYL INSULATED  
FORK .170 MAX WIRE INSUL DIA

REV	DATE	BY	DESCRIPTION	DRAWN BY	CHK'D	SCALE	DRAWING NO.
05	8/10	SRB	Changed "A" dimensions .88 was .83, .95 was .89, .97 was .91 Removed tolerances from A,W,C,M,H dimensions	DRL		NONE	A41459