

THIS COPY IS PROVIDED ON A RESTRICTED BASIS AND IS NOT TO BE USED IN ANY WAY DETRIMENTAL TO THE INTERESTS OF PANDUIT CORP.

PANDUIT PART NUMBER	STUD SIZE	DIMENSIONS in.				
		A $\pm .04$	W $\pm .01$	C $\pm .02$	M $\pm .04$	H $\pm .01$
PNF10-6LF	#6	1.02 (25.91)	.30 (7.62)	.20 (5.08)	.79 (20.07)	.14 (3.56)
PNF10-8LF	#8	1.05 (26.67)	.30 (7.62)	.20 (5.08)	.79 (20.07)	.16 (4.06)
PNF10-10LF	#10	1.05 (26.67)	.34 (8.64)	.22 (5.59)	.79 (20.07)	.19 (4.83)
PNF10-14LF	1/4"	1.19 (30.23)	.46 (11.68)	.33 (8.38)	.90 (22.86)	.25 (6.35)

NOTES:

- UL LISTED AND CSA CERTIFIED FOR:
 - 600V. MAX. BLDG WIRE (1000V. MAX IN SIGNS, FIXTURES & LUMINARIES)
 - #14-10 AWG SOLID OR STRANDED COPPER WIRE WITH THE CT-550 INSTALLATION TOOL.
 - #12-10 AWG STRANDED AND #12 AWG SOLID COPPER WIRE WITH THE CT-1550 AND 1551 INSTALLATION TOOLS.
 - 221° F (105° C) MAX. TEMP. RATING
- MATERIAL:
 - STAMPING - .04" (1.02) THK. COPPER, TIN PLATED
 - HOUSING - NYLON YELLOW
 - SLEEVE - BRASS, TIN PLATED
- PACKAGE QTY: -L = 50
-D = 100
- WIRE STRIP LENGTH: $9/32 \pm 1/32$
- DIMENSIONS IN BRACKETS ARE IN MILLIMETERS

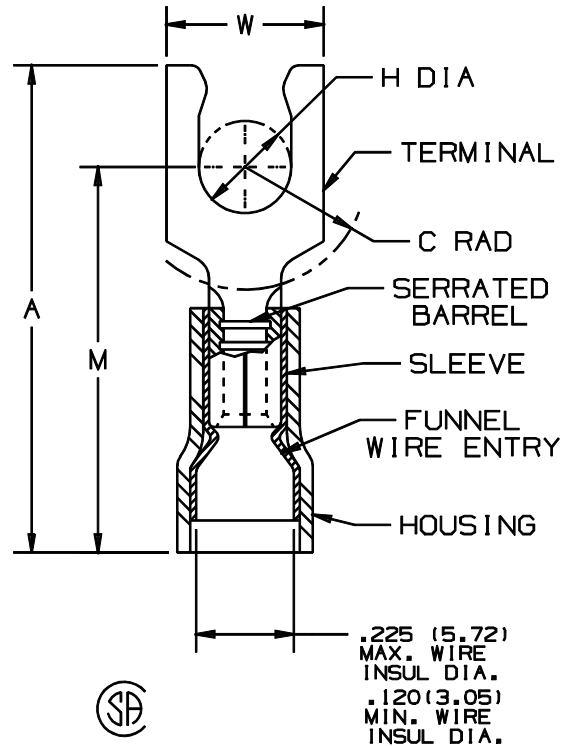

UL LISTED 587H E52164

CSA CERTIFIED LR31212

A41295_07

07	1/01	RM		FILESPEC WAS N41295AA_PCD_06							
6	5/99	ED		UPDATED "A" & "M" DIM'S, AND MODIFIED DIMENSIONAL TOLERANCES	07664						
5	12-96	JAMB	RLS	ADDED DIM. MIN. WIRE INSUL DIA. UPDATE NOTES	05434	LA	DBH				
4	3-95	MS	RLS	UPDATED NOTES AND DIMENSIONS	03074	KS	LA				
REV	DATE	BY	CHK	DESCRIPTION	ECN #	CUST	PM	DRAWN BY	CHK'D	SCALE	DRAWING NO.
								DAW	RLS	NONE	A41295

PANDUIT CORP. TINLEY PARK, ILLINOIS

#12-10 BARREL NYLON INSULATED LOCKING FORK, FUNNELED WIRE ENTRY, .225 (5.72) MAX. WIRE INSULATION DIAMETER