

THIS COPY IS PROVIDED ON A RESTRICTED BASIS AND IS NOT TO BE USED IN ANY WAY DETRIMENTAL TO THE INTERESTS OF PANDUIT CORP.

PANDUIT PART NUMBER	STUD SIZE	DIMENSIONS in.				
		A $\pm .04$	W $\pm .01$	C $\pm .02$	M $\pm .04$	H $\pm .01$
PNF10-6F	#6	1.01 (25.65)	.31 (7.87)	.24 (6.10)	.80 (20.32)	.15 (3.81)
PNF10-8F	#8	1.02 (25.91)	.37 (9.40)	.24 (6.10)	.80 (20.32)	.17 (4.32)
PNF10-10F	#10	1.04 (26.42)	.37 (9.40)	.24 (6.10)	.80 (20.32)	.20 (5.08)
PNF10-14F	1/4"	1.15 (29.21)	.50 (12.7)	.31 (7.87)	.90 (22.86)	.27 (6.86)

NOTES:

- UL LISTED AND CSA CERTIFIED FOR:
 - 600V. MAX. BLDG. WIRE (1000V. MAX. IN SIGNS, FIXTURES & LUMINARIES)
 - #14-10 AWG SOLID OR STRANDED COPPER WIRE WITH THE CT-550 INSTALLATION TOOL.
 - #12-10 AWG STRANDED AND #12 AWG SOLID COPPER WIRE WITH THE CT-1550 AND CT-1551 INSTALLATION TOOLS.
 - #12-10 AWG SOLID OR STRANDED COPPER WIRE WITH THE CT-100 INSTALLATION TOOL.
 - 221° F (105° C) MAX. TEMP. RATING
- MATERIAL:
 - STAMPING - .04" (1.02) THK COPPER, TIN PLATED
 - HOUSING - NYLON, YELLOW
 - SLEEVE - BRASS, TIN PLATED
- WIRE STRIP LENGTH: $9/32 \pm 1/32$
- PACKAGE QTY: -L = 50
-D = 500
- DIMENSIONS IN BRACKETS ARE IN MILLIMETERS.

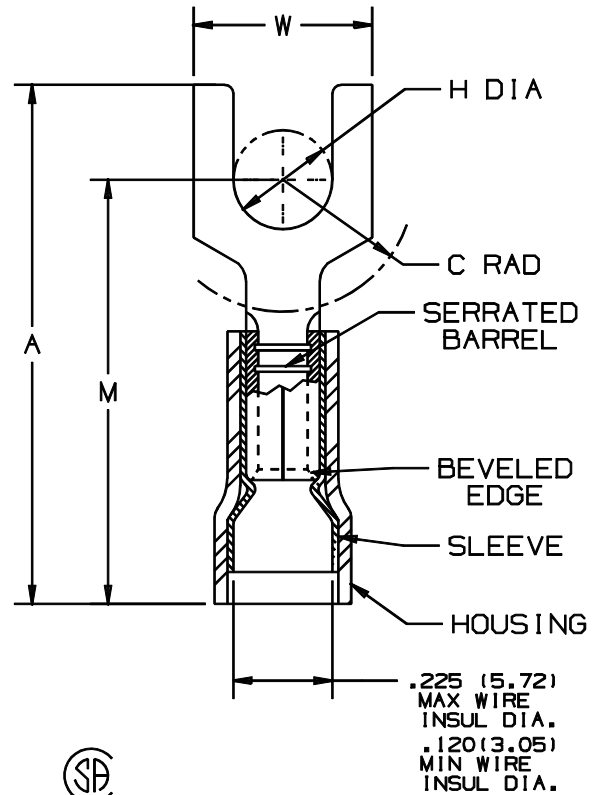

LISTED
587H
E52164



CERTIFIED
LR31212

A41262_06

REV	DATE	BY	CHK	DESCRIPTION	ECN #	CUST	PM	DRAWN BY	CHK'D	SCALE	DRAWING NO.
6	1/01	RM		FILESPEC WAS N41262AA_PCD_05							
5	5/99	ED		UPDATED "A" & "M" DIM.S, AND MODIFIED DIMENSIONAL TOLERANCES	07685						
4	12/96	JAM/RLS		ADDED DIM. "MIN. WIRE INSUL. DIA." UPDATE NOTES	05430	LA	DBH				
3	3/95	MS/RLS		UPDATED NOTES AND DIMENSIONS	03075	KS	LA				
								DAW	LA	NONE	A41262

PANDUIT

CORP.

TINLEY PARK, ILLINOIS

#12-10 BARREL FORK, NYLON INSULATED FUNNELED WIRE ENTRY, .225 (5.72) MAX. WIRE INSULATION DIAMETER