

THIS COPY IS PROVIDED ON A RESTRICTED BASIS AND IS NOT TO BE USED IN ANY WAY DETRIMENTAL TO THE INTERESTS OF PANDUIT CORP.

PART NUMBER	STUD SIZE	WIRE RANGE AWG	DIMENSIONS (in.)				
			A $\pm$ .03	W $\pm$ .01	C $\pm$ .01	M $\pm$ .02	H $\pm$ .02
PN22-2F	#2	#26-22	.66 (16.76)	.20 (5.08)	.19 (4.85)	.56 (14.22)	.09 (2.28)

NOTES

- RECOMMENDED FOR:
  - 300V MAX. VOLTAGE RATING
  - #26-22 AWG SOLID OR STRANDED COPPER WIRE
  - 221°F (105°C) MAX TEMP. RATING
- MATERIAL:
  - STAMPING: .020 (0.51) THK COPPER, TIN PLATED.
  - HOUSING: YELLOW NYLON
  - SLEEVE: TIN PLATED BRASS
- PACKAGE QUANTITY: -C = 100  
-M = 1000
- DIMENSIONS IN BRACKETS ARE IN MILLIMETERS
- INSTALLATION TOOLS: CT-520, CT-1525
- WIRE STRIP LENGTH :  $3/16 \text{ }^{+1/32}_{-0}$  (4.76  $^{+0.8}_{-0}$ )

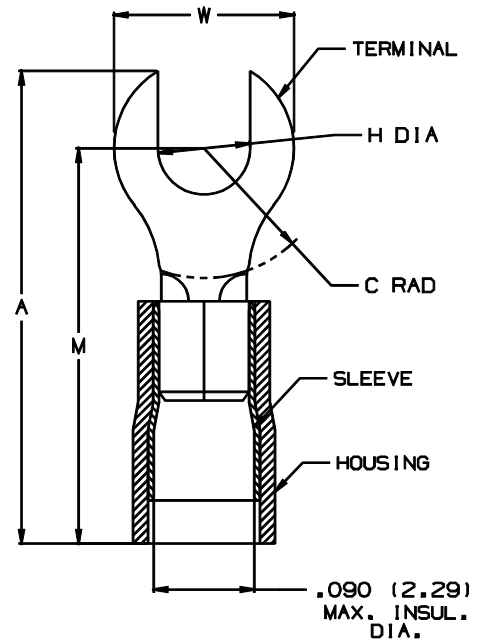

A41234\_01

										<b>PANDUIT</b> CORP.		TINLEY PARK, ILLINOIS				
01		JKD	ADDED CT-1525 TOOL								#26-22 BARREL NYLON INSULATED FORK					
00	7/97	TM	RLS	RELEASED				06083		LCA	RM					
REV	DATE	BY	CHK	DESCRIPTION				ECN #	QA	CUST	PM	APP	DRAWN BY	CHK'D	SCALE	DRAWING NO.
													T SMA	RLS	NONE	A41234