

THIS COPY IS PROVIDED ON A RESTRICTED BASIS AND IS NOT TO BE USED IN ANY WAY DETRIMENTAL TO THE INTERESTS OF PANDUIT CORP.

PANDUIT PART NUMBER	STUD SIZE	DIMENSIONS in.				
		A $\pm .03$	W $\pm .01$	C $\pm .02$	M $\pm .03$	H $\pm .01$
PNF14-6LF	#6	.87 (22.10)	.25 (6.35)	.20 (5.08)	.65 (16.51)	.14 (3.56)
PNF14-6LFW	#6	.84 (21.34)	.29 (7.37)	.20 (5.08)	.65 (16.51)	.14 (3.56)
PNF14-8LF	#8	.93 (23.62)	.29 (7.37)	.25 (6.35)	.70 (17.78)	.16 (4.06)
PNF14-10LF	#10	.93 (23.62)	.33 (8.38)	.25 (6.35)	.70 (17.78)	.19 (4.83)

NOTES:

- UL LISTED AND CSA CERTIFIED FOR:
 - 600V. MAX. BLDG WIRE (1000 V. MAX IN SIGNS, FIXTURES & LUMINAIRES),
 - #18-14 AWG SOLID OR STRANDED COPPER WIRE WITH THE CT-550, CT-500, CT-1550, CT-1551, CT-460 (UL ONLY) AND CT-400 (UL ONLY) INSTALLATION TOOLS.
 - #16-14 AWG SOLID OR STRANDED COPPER WIRE WITH THE CT-100 AND CT-250 INSTALLATION TOOLS.
 - 221°F (105°C) MAX TEMP. RATING
- MATERIAL:
 - STAMPING - .032" (.81) THK COPPER, TIN PLATED
 - HOUSING - NYLON, BLUE
 - SLEEVE - BRASS, TIN PLATED
- STRIP LENGTH - 7/32 $\pm \frac{1}{32}$ $\frac{0}{0}$
- PACKAGE QTY: -C=100
-M=1000
- DIMENSIONS IN BRACKETS ARE IN MILLIMETERS

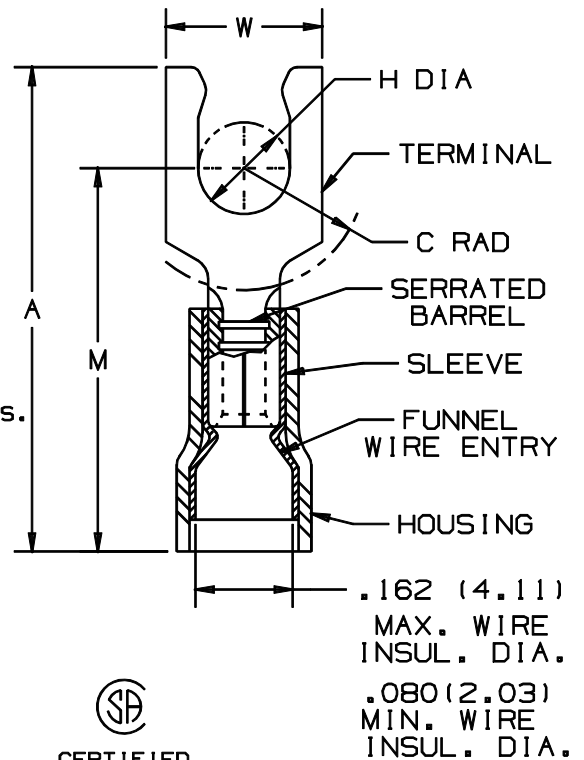

LISTED
587H
E52164



CERTIFIED
LR31212

A41294_07

7	1/01	RM		FILESPEC WAS N41294AA_PCD_06															
6	12-96	JAMB		ADDED DIM. "MIN. WIRE INSUL. DIA." UPDATED NOTES	05386														
5	3-95	MS	RLS	UPDATED NOTES AND DIMENSIONS	03049	LA	KRS												
4	8-88	DW					JB												
REV	DATE	BY	CHK	DESCRIPTION	ECN #	CUST	PM	DRAWN BY	CHK'D	SCALE	NONE	DRAWING NO.	A41294						

PANDUIT

CORP.

TINLEY PARK, ILLINOIS

#16-14 BARREL NYLON INSULATED LOCKING FORK, FUNNELED WIRE ENTRY, .162 (4.11) MAX. WIRE INSULATION DIAMETER