

4

3

2

1

THIS DRAWING IS UNPUBLISHED. RELEASED FOR PUBLICATION
 © COPYRIGHT - BY TYCO ELECTRONICS CORPORATION. ALL RIGHTS RESERVED.

LOC	DIST	REVISIONS			
P	LTR	DESCRIPTION	DATE	DWN	APVD
G1		REV PER 0G3A-0668-04	25AUG04	JR	TM

AMP WIRE RANGE	Listed FILE E13288	LR7189 Certified
12-10 AWG SOLID OR STRANDED	12 AWG STRANDED	12-10 AWG SOLID OR STRANDED

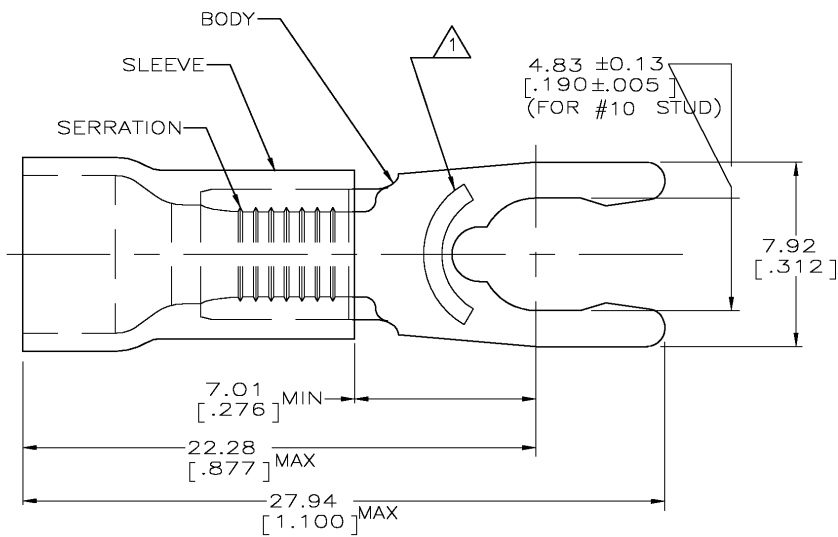

1. STAMP 10S AMP 12-10* APPROX AS SHOWN
2. WIRE INSUL DIA, 3.81-6.35 [.150-.250]
3. TONGUE MATL THK, 1.02±0.05 [.040±.002]
4. MATERIAL: BODY - BRASS PER ASTM B36
SLEEVE - PVC, COLOR - YELLOW

2500	ON TAPE, REEL	53248-2
500	LOOSE PIECE	53248-1
QTY	PACKAGE TYPE	PART NO

AMP INCORPORATED CUSTOMER SERVICE SYSTEMS		MAX RECOMMENDED OPERATING TEMPERATURE: 105°C [221°F]	THIS DRAWING IS A CONTROLLED DOCUMENT.		DWN L OLMEDA 26JUN95	Tyco Electronics Corporation Harrisburg, Pa 17105-3608	
FOR ADDITIONAL PRODUCT INFORMATION OR COPIES OF DRAWINGS AND TECHNICAL DOCUMENTS	PRODUCT INFORMATION CENTER 1-800-522-6752	VOLTAGE RATING: 600V MAX (1000V FIXTURE OR SIGN)	DIMENSIONS: mm [INCHES]	TOLERANCES UNLESS OTHERWISE SPECIFIED:	CHK M ELLIS 26JUN95		NAME G NGO 26JUN95
FOR APPLICATION	TOOLING ASSISTANCE CENTER 1-800-722-1111	CIRCULAR MIL AREA: 2.62-6.64mm² [5,180-13,100] SOLID OR STRANDED		0 PLC ± - 1 PLC ± - 2 PLC ± 0.20 [.008] 3 PLC ± - 4 PLC ± - ANGLES ± -	APVD G NGO 26JUN95	PRODUCT SPEC UL 486A	
TOOLING INFORMATION	1-800-722-1111		MATERIAL	FINISH TIN PER ASTM B545	APPLICATION SPEC	SIZE CAGE CODE DRAWING NO A3 00779 C-53248	RESTRICTED TO
FOR ORDER ENTRY	1-800-526-5142	THIS DRAWING IS A CONTROLLED DOCUMENT FOR AMP INCORPORATED. IT IS SUBJECT TO CHANGE AND THE CONTROLLING ENGINEERING ORGANIZATION SHOULD BE CONTACTED FOR THE LATEST REVISION.	MATERIAL	FINISH	WEIGHT	A3 00779 C-53248	SCALE 6:1 SHEET 1 OF 1 REV G1

AMP 1470-19 REV 31MAR2000