

4

3

2

1

THIS DRAWING IS UNPUBLISHED. RELEASED FOR PUBLICATION
 © COPYRIGHT - BY TYCO ELECTRONICS CORPORATION. ALL INTERNATIONAL RIGHTS RESERVED.

LOC	DIST	REVISIONS				
P	LTR	DESCRIPTION	DATE	DWN	APVD	
G	14	REV PER ECR 10-005023	05MAR10	JR	TM	

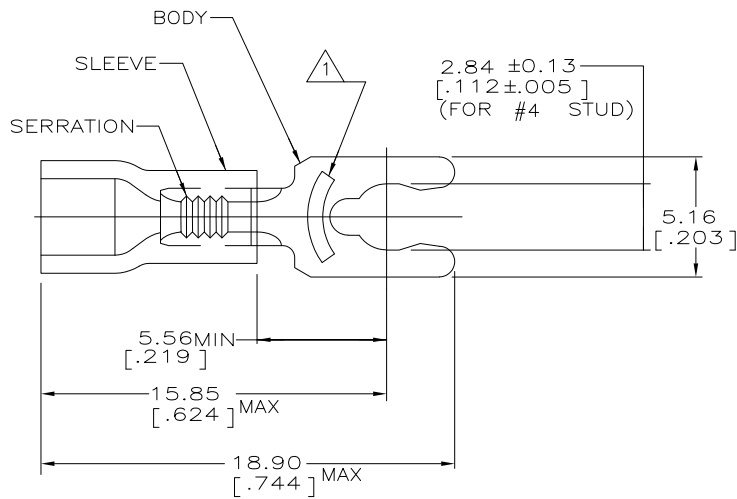

AMP WIRE RANGE	Listed FILE E13288	LR7189 Certified
24-20 AWG SOLID OR STRANDED	24-20 AWG SOLID OR STRANDED	24-20 AWG SOLID OR STRANDED

- ① STAMP 4S AMP 24-20 APPROX AS SHOWN
2. WIRE INSUL DIA, 2.03-3.18 [.080-.125]
3. TONGUE MATL THK, 0.58±0.05 [.023±.002]
- ④ MATERIAL: BODY: PHOS BRONZE PER ASTM B139
 SLEEVE: PVC, COLOR - WHITE

-	-	-
5000	ON TAPE, REEL	53829-2
QTY	PACKAGE TYPE	PART NO

AMP INCORPORATED CUSTOMER SERVICE SYSTEMS		MAX RECOMMENDED OPERATING TEMPERATURE: 90°C [194°F]	THIS DRAWING IS A CONTROLLED DOCUMENT.		DWN L OLMEDA 26JUN95	Tyco Electronics Corporation Harrisburg, PA 17105-3608	
FOR ADDITIONAL PRODUCT INFORMATION OR COPIES OF DRAWINGS AND TECHNICAL DOCUMENTS	PRODUCT INFORMATION CENTER 1-800-522-6752	VOLTAGE RATING: 600V MAX (1000V FIXTURE OR SIGN)	DIMENSIONS: mm [NCHES]	TOLEANCES UNLESS OTHERWISE SPECIFIED:	CHK M ELLIS 26JUN95	NAME G NGO 26JUN95	
FOR APPLICATION	TOOLING ASSISTANCE CENTER 1-800-722-1111	CIRCULAR MIL AREA: 0.16-0.65mm² [320-1290] SOLID OR STRANDED		0 PLC ± - 1 PLC ± - 2 PLC ± 0.20 [.008] 3 PLC ± - 4 PLC ± - ANGLES ± -	APVD G NGO 26JUN95	PRODUCT SPEC UL 486A	
TOOLING INFORMATION	1-800-722-1111	THIS DRAWING IS A CONTROLLED DOCUMENT FOR AMP INCORPORATED. IT IS SUBJECT TO CHANGE AND THE CONTROLLING ENGINEERING ORGANIZATION SHOULD BE CONTACTED FOR THE LATEST REVISION.	MATERIAL ④	FINISH TIN PL PER ASTM B545	APPLICATION SPEC -	SIZE A3	CAGE CODE 00779
FOR ORDER ENTRY	1-800-526-5142				WEIGHT -	DRAWING NO C-53829	RESTRICTED TO -
					CUSTOMER DRAWING	SCALE 6:1	SHEET 1 OF 1
						REV E	

1470-19 (1/08)