

THIS DRAWING IS UNPUBLISHED. RELEASED FOR PUBLICATION
 © COPYRIGHT 19 BY AMP INCORPORATED. ALL INTERNATIONAL RIGHTS RESERVED.

LOC	DIST	P	F	ZONE	LTR	DESCRIPTION	DATE	APPD
G	14				F	REV & REDRAWN PER 0720-0040-93	3-28-93	APPD

METRIC
 DIMENSIONS LISTED IN mm [INCHES]

AMP WIRE RANGE	UL E13288 Listed
12-10 AWG SOLID OR STRANDED	12-10 AWG STRANDED
UL LR7189 Certified	MILITARY P/N AND CLASS
12-10 AWG SOLID OR STRANDED	NOT APPLICABLE

△ STAMP 10S AMP 12-10* APPROX AS SHOWN
 10S INDICATES STUD SIZE

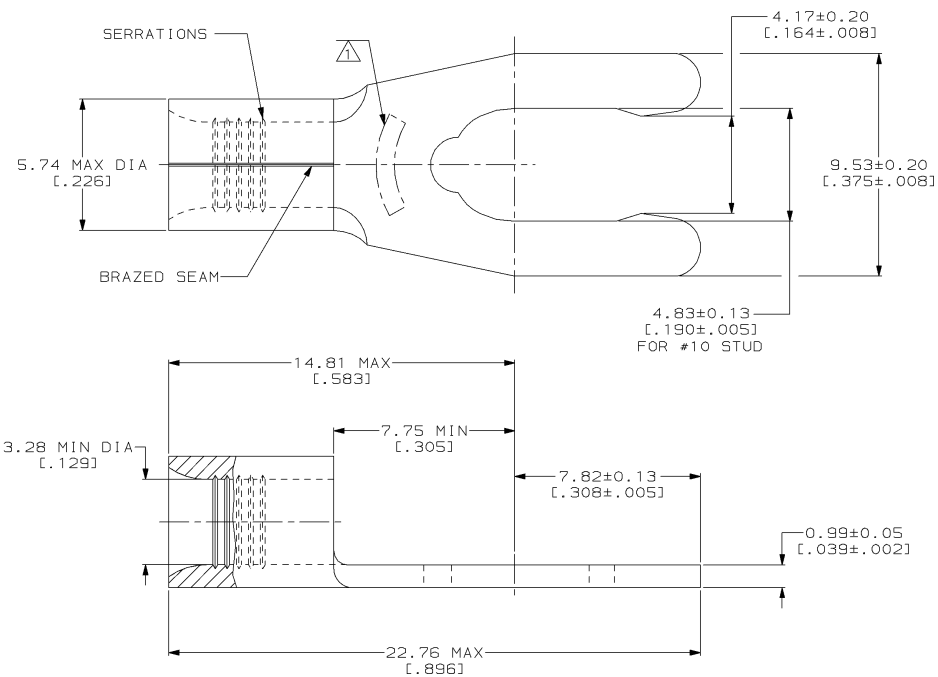

2500	ON TAPE	52717-2
----	LOOSE PIECE	52717-1
QUANTITY	PACKAGING TYPE	PART NO

AMP INCORPORATED
CUSTOMER SERVICE SYSTEMS

FOR ADDITIONAL PRODUCT INFORMATION OR COPIES OF DRAWINGS AND TECHNICAL DOCUMENTS

PRODUCT INFORMATION CENTER
 1-800-522-6752

FOR APPLICATION TOOLING INFORMATION

TOOLING ASSISTANCE CENTER
 1-800-722-1111

FOR ORDER ENTRY

1-800-526-5142

MAX RECOMMENDED OPERATING TEMPERATURE:
 170°C MAX

VOLTAGE RATING:
 NOT APPLICABLE

WIRE CROSS SECTIONAL AREA RANGE:
 2.62-6.64mm² [5,180-13,100] CIR MILS
 SOLID OR STRANDED

THIS DRAWING IS A CONTROLLED DOCUMENT FOR AMP INCORPORATED. IT IS SUBJECT TO CHANGE AND THE CONTROLLING ENGINEERING ORGANIZATION SHOULD BE CONTACTED FOR THE LATEST REVISION.

DO NOT SCALE PRINT.
 UNLESS SPECIFIED DIMENSIONS IN mm (INCHES)
 TOLERANCES ON:
 2 PLC DEC ± -
 3 PLC DEC ± -
 ANGLES ± -

MATERIAL
 PHOSPHOR BRONZE
 PER ASTM B-103
 ANNEALED

FINISH
 T1N PLATE
 0.00254 [0.00100] MIN
 THK PER MIL-T-10727

DR 3-28-93
 TA BRINKMAN

CHK 3-28-93
 DA PATTERSON

APPD 3-28-93
 DE MILLER

APPD 3-28-93
 JL MECKLEY

APPLICATION SPEC
 -

WEIGHT
 -

AMP AMP Incorporated
 Harrisburg, PA 17105-3608

NAME
**TERMINAL, LONG
 SPRING SPADE, SOLISTRAND™**

SIZE
 © 00779

DRAWING NO
 ©=52717

SCALE 8:1

SHEET 1 OF 1

AMP 1471-6 REV 3-92
 10_SEP_1993 12:55:33 AMP26463 <U5128A>DEPT1123>DWG1123>U_SOL1STRAND>U_INL_INE

CUSTOMER DRAWING