

© COPYRIGHT 19 BY AMP INCORPORATED. ALL INTERNATIONAL RIGHTS RESERVED.

G 14		REVISE		REVISIONS		DATE	APPRO
ZONE	LTR	DESCRIPTION	DATE	APPRO	DATE	APPRO	DATE
A		REVISED PER 0720-0230-93	2/28/94				

METRIC
DIMENSIONS LISTED IN mm [INCHES]

AMP WIRE RANGE	E13288 Listed
12-10 AWG STRANDED	12-10 AWG STRANDED
LR7189 Certified	MILITARY P/N AND CLASS
NOT CERTIFIED	NOT APPLICABLE

STAMP 105 AMP 12-10* APPROX AS SHOWN
105 INDICATES STUD SIZE

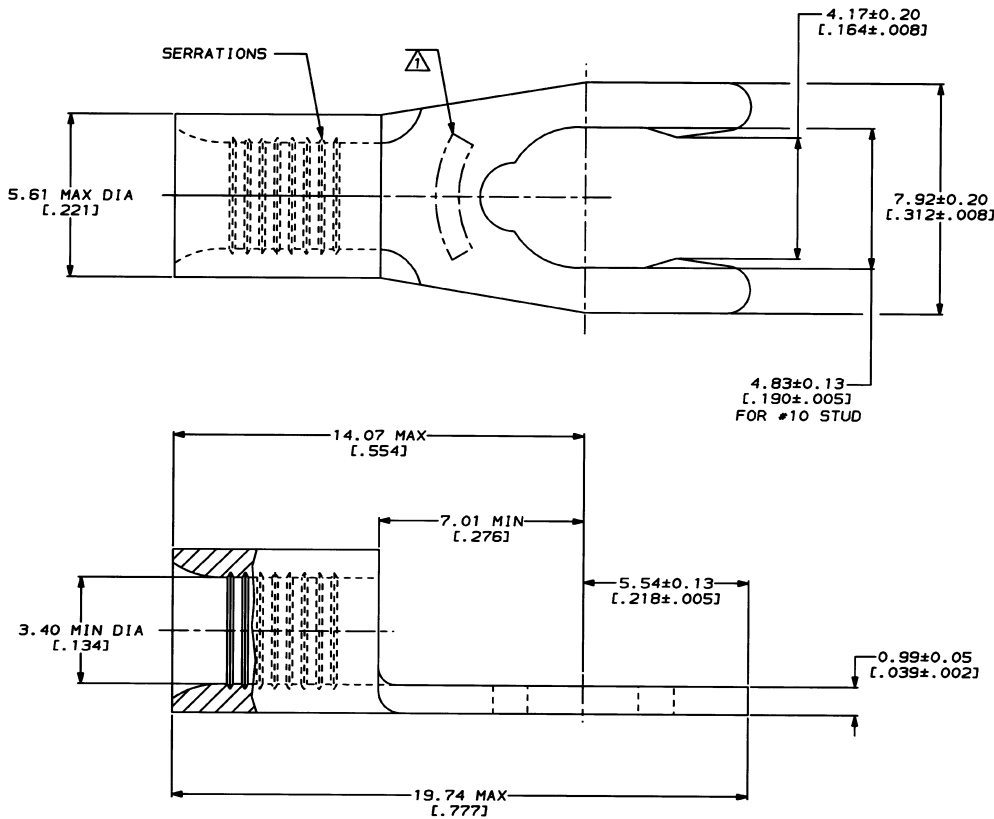

**AMP INCORPORATED
CUSTOMER SERVICE SYSTEMS**

FOR ADDITIONAL
PRODUCT INFORMATION OR
COPIES OF DRAWINGS
AND TECHNICAL DOCUMENTS

PRODUCT INFORMATION CENTER
1-800-522-6752

FOR APPLICATION
TOOLING INFORMATION

TOOLING ASSISTANCE CENTER
1-800-722-1111

FOR ORDER ENTRY

1-800-526-5142

MAX RECOMMENDED OPERATING
TEMPERATURE:

170°C MAX

VOLTAGE RATING:

NOT APPLICABLE

WIRE CROSS SECTIONAL AREA RANGE:

2.62-6.64mm² (5, 180-13, 100) CIR MILS
STRANDED

THIS DRAWING IS A CONTROLLED DOCUMENT FOR
AMP INCORPORATED. IT IS SUBJECT TO CHANGE
WITHOUT NOTICE. FOR THE LATEST REVISION,
REFER TO THE DRAWING FOR THE LATEST REVISION.

DO NOT SCALE PRINT.
UNLESS SPECIFIED
DIMENSIONS IN ——— (INCHES)
TOLERANCES ON :
2 PLC DEC ± —
3 PLC DEC ± —
ANGLES ± —

MATERIAL
PHOSPHOR BRONZE
PER ASTM B-103
ANNEALED

FINISH
TIN PLATE
0.00254 [.000100] MIN
THK PER MIL-T-10727

DR 2-12-93
TA BRINKMAN

CHK 2-12-93
DA PATTERSON

APPD 2-12-93
DE MILLER

APPD 2-12-93
JL MECKLEY

PRODUCT SPEC
-

APPLICATION SPEC
-

WEIGHT
-

AMP AMP Incorporated
Harrisburg, PA 17105-3608

NAME
**TERMINAL, SHORT
SPRING SPADE, BUDGET**

SIZE CAGE CODE 00779 DRAWING NO C-53274

SCALE 10:1 SHEET 1 OF 1

53274-2
PART NO

CUSTOMER DRAWING