

DRAWING MADE IN THIRD ANGLE PROJECTION
 THIS DRAWING IS UNPUBLISHED. RELEASED FOR PUBLICATION
 © COPYRIGHT 19 BY AMP INCORPORATED. ALL INTERNATIONAL RIGHTS RESERVED.

LOC	DIST	P	F	ZONE	LTR	REVISIONS	DATE	APPD
G	14				0	RELEASED PER 0720-0008-93	3-1-93	JAP

METRIC
 DIMENSIONS LISTED IN mm [INCHES]

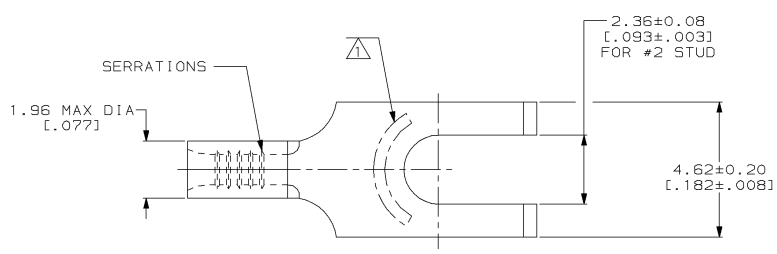

AMP WIRE RANGE	UL E13288 Listed
26-22 AWG STRANDED	NOT LISTED
CS LR7189 Certified	MILITARY P/N AND CLASS
NOT CERTIFIED	NOT APPLICABLE

△ STAMP AMP APPROX AS SHOWN

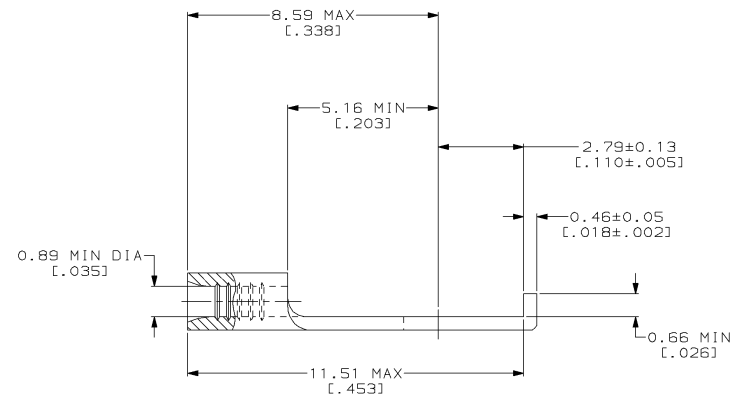

AMP INCORPORATED
CUSTOMER SERVICE SYSTEMS

FOR ADDITIONAL PRODUCT INFORMATION OR COPIES OF DRAWINGS AND TECHNICAL DOCUMENTS	PRODUCT INFORMATION CENTER 1-800-522-6752
FOR APPLICATION TOOLING INFORMATION	TOOLING ASSISTANCE CENTER 1-800-722-1111
FOR ORDER ENTRY	1-800-526-5142

MAX RECOMMENDED OPERATING TEMPERATURE:
170°C MAX

VOLTAGE RATING:
NOT APPLICABLE

WIRE CROSS SECTIONAL AREA RANGE:
0.1-0.41mm² [202-810] CIR MILS STRANDED

THIS DRAWING IS A CONTROLLED DOCUMENT FOR AMP INCORPORATED. IT IS SUBJECT TO CHANGE AND THE CONTROLLING ENGINEERING ORGANIZATION SHOULD BE CONTACTED FOR THE LATEST REVISION.

DO NOT SCALE PRINT.
 UNLESS SPECIFIED DIMENSIONS IN mm [INCHES] TOLERANCES ON:
 2 PLC DEC ± -
 3 PLC DEC ± -
 ANGLES ± -

MATERIAL
 COPPER PER ASTM B-152 ANNEALED

FINISH
 T1N PLATE
 0.00254 [0.00100] MIN THK PER MIL-T-10727

DR 3-1-93
TA BRINKMAN

CHK 3-1-93
DA PATTERSON

APPD 3-1-93
DE MILLER

APPD 3-1-93
JL MECKLEY

PRODUCT SPEC
-

APPLICATION SPEC
-

WEIGHT
-

324599
PART NO

AMP AMP Incorporated
Harrisburg, PA 17105-3608

NAME
TERMINAL, FLANGED SPADE, BUDGET

SIZE
 © 00779

CAGE CODE
 ©-324599

DRAWING NO
 ©-324599

SCALE 10:1

SHEET 1 OF 1