

REV	DATE	BY	REVISIONS
1	07/20/93	0230-0230-93	REVISED PER 0720-0230-93

**METRIC**  
 DIMENSIONS LISTED IN MM [ INCHES ]

<b>AMP</b> WIRE RANGE 16-14 AWG STRANDED	<b>UL</b> E13288 Listed 16-14 AWG STRANDED
<b>LR7189</b> Certified	MILITARY P/N AND CLASS
NOT CERTIFIED	NOT APPLICABLE

△ STAMP AMP 16-14\* APPROX AS SHOWN

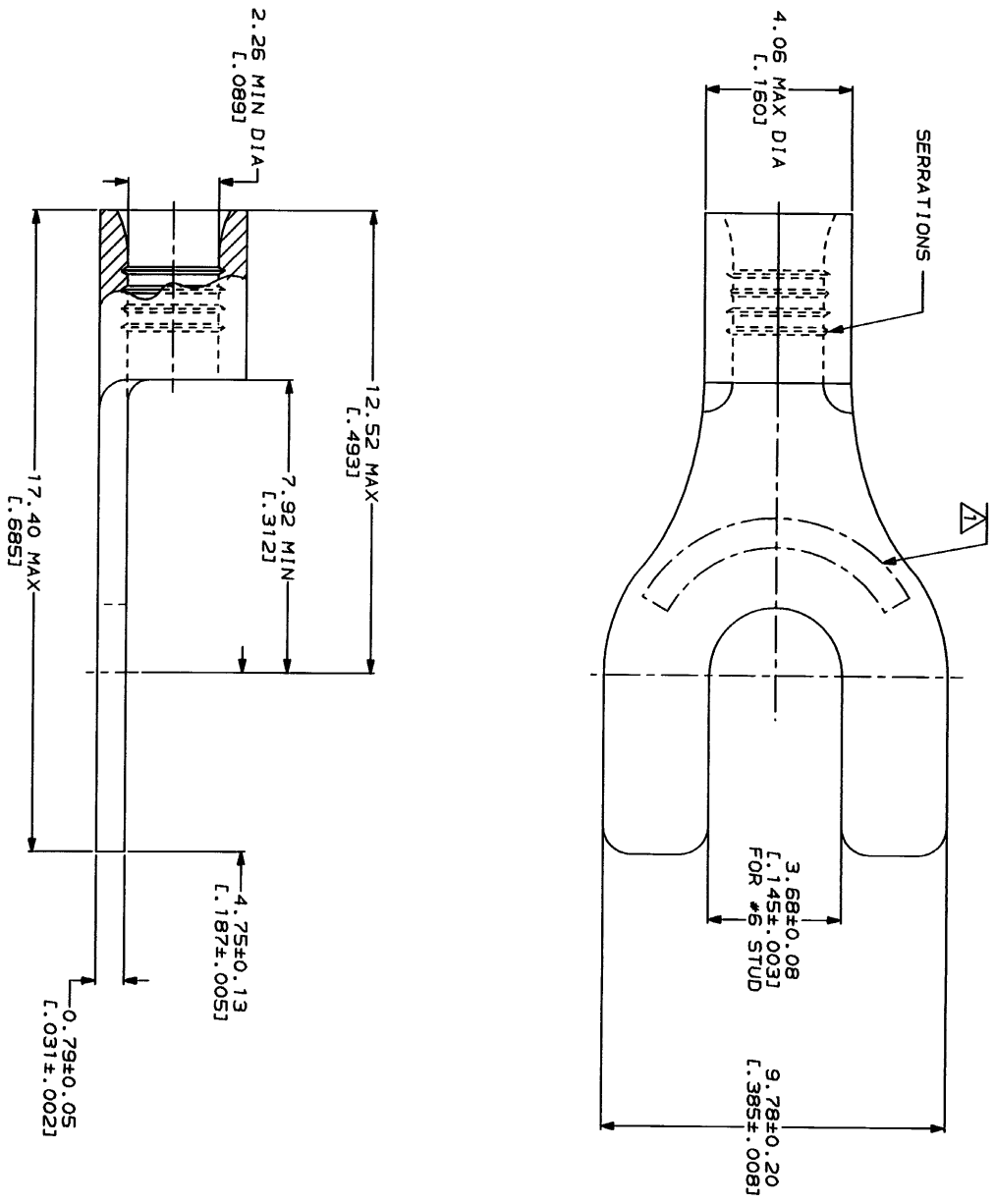

**AMP INCORPORATED**  
 CUSTOMER SERVICE SYSTEMS

FOR ADDITIONAL PRODUCT INFORMATION OR COPIES OF DRAWINGS AND TECHNICAL DOCUMENTS	PRODUCT INFORMATION CENTER 1-800-522-6752	MAX RECOMMENDED OPERATING TEMPERATURE: 170°C MAX
FOR APPLICATION TOOLING INFORMATION	TOOLING ASSISTANCE CENTER 1-800-722-1111	VOLTAGE RATING: NOT APPLICABLE
FOR ORDER ENTRY	1-800-526-5142	WIRE CROSS SECTIONAL AREA RANGE, 1.04-2.62mm <sup>2</sup> [2.050-5.180] CIR MILS STRANDED

DO NOT SCALE PRINT. UNLESS SPECIFIED DIMENSIONS IN PARENTHESES ON 1 PLG DEC 2 1983	DR 2-17-93 TA BRINKMAN	<b>AMP</b> AMP Incorporated Harrisburg, PA 17105-3508
MATERIAL COPPER PER ASTM B-152 ANNEALED	CHK 2-17-93 DA PATTERSON	
FINISH TIN PLATE 0.00254 [1.0001001] MIN THK PER MIL-T-10727	APPD 2-17-93 DE HILLER	NAME <b>AMP</b> AMP Incorporated Harrisburg, PA 17105-3508
APPLICATION SPEC	APPD 2-17-93 JL NECKLEY	
SCALE 10:1	SIZE CAGE CODE 00779	DRAWING NO 31704

CUSTOMER DRAWING  
 1 OF 1