

REV	DATE	APPROV	DESCRIPTION
0	2-16-93		RELEASED PER 0720-0008-93

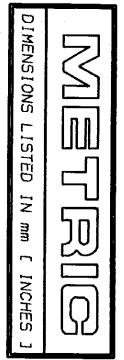

AMP WIRE RANGE 26-22 AWG STRANDED	UL E13288 Listed
UL LR7189 Certified	MILITARY P/N AND CLASS
NOT CERTIFIED	NOT APPLICABLE

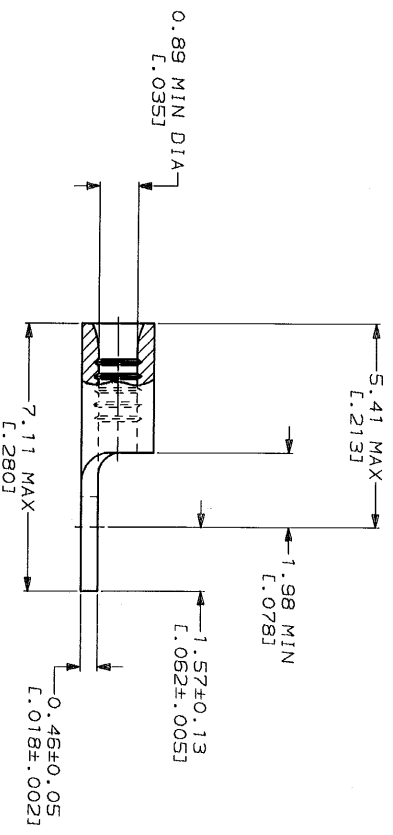
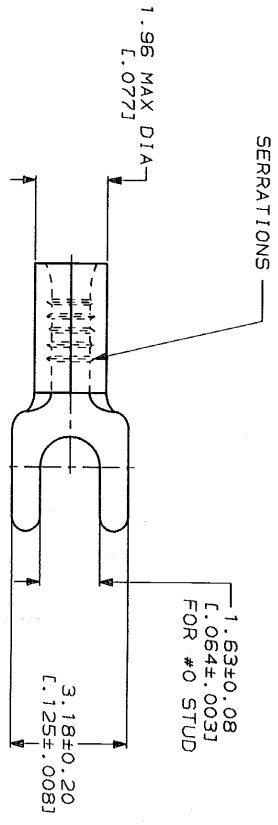

**AMP INCORPORATED
CUSTOMER SERVICE SYSTEMS**

FOR ADDITIONAL PRODUCT INFORMATION OR COPIES OF DRAWINGS AND TECHNICAL DOCUMENTS	PRODUCT INFORMATION CENTER 1-800-522-6752
FOR APPLICATION TOOLS AND TOOLS INFORMATION	TOOLING ASSISTANCE CENTER 1-800-722-1111
FOR ORDER ENTRY	1-800-526-5142

MAX RECOMMENDED OPERATING TEMPERATURE: 170°C MAX

VOLTAGE RATINGS: NOT APPLICABLE

WIRE CROSS SECTIONAL AREA RANGE: 0.1-0.41mm² [202-810] CIR MILS STRANDED

DO NOT SCALE PRINT. UNLESS SPECIFIED DIMENSIONS IN MILLIMETERS - TOLERANCES ON: 1. 2 PL DEC ± .1 3. PL DEC ± .1 ANGLES MATERIAL COPPER PER ASTM B-152 ANNEALED

FINISH TIN PLATE 0.00254 [L.0001001] MIN THK PER MIL-T-10727

OR 2-16-93 TA BRINKMAN	CHK 2-16-93 DA PATTERSON
APPD 2-16-93 DE MILLER	APPD 2-16-93 JL MECKLEY
PRODUCT SPEC	

AMP	AMP Incorporated Harrisburg, PA 17105-3608
NAME	TERMINAL, SPADE TONGUE, BUDGET
SIZE	GAGE CODE 00779
SCALE	10:1
DRAWING NO	32501
SHEET	1 OF 1