

4

3

2

1

THIS DRAWING IS UNPUBLISHED. RELEASED FOR PUBLICATION
 © COPYRIGHT BY TYCO ELECTRONICS CORPORATION. ALL RIGHTS RESERVED.

LOC	DIST	REVISIONS			
P	LTR	DESCRIPTION	DATE	MIN	APPROV
AF	50	H	REV & REDRAWN PER 063A-0200-02	02APR03	MF DD

- FOR NEW APPLICATIONS SEE PREFERRED MODERNIZED DESIGN 42320 GROUP AND 42321 GROUP.
- △ SUFFIX LETTER MUST BE USED ONLY WHEN ORDERING APPLICATOR TOOLING.
- CONTINUOUS STRIP ON REELS.

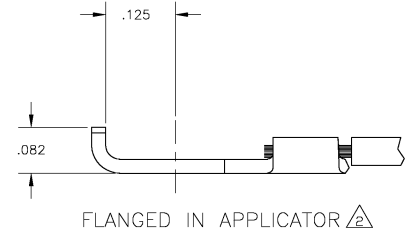
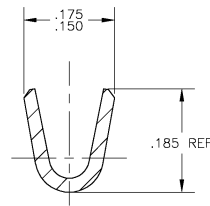
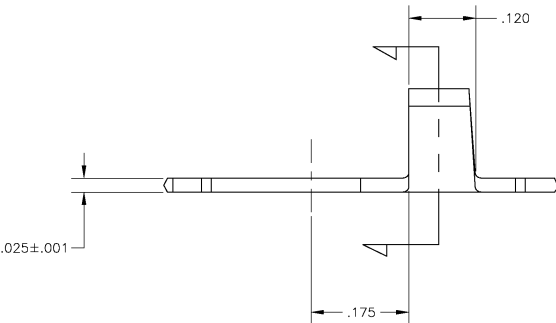
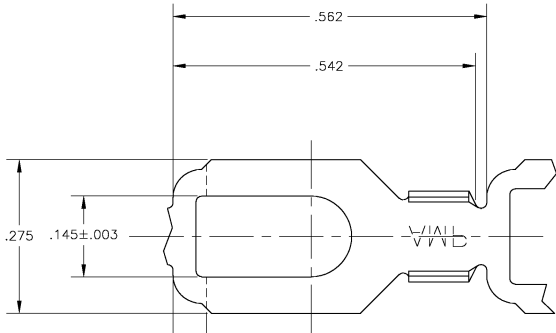

40577 A	18-14 AWG	40577
△	FLANGED PART NUMBER	WIRE RANGE PART NUMBER

THIS DRAWING IS A CONTROLLED DOCUMENT.		DWG: MICHAEL S. FEHLER CK: DONALD F. DECKER PWD: DONALD F. DECKER PRODUCT SPEC:		Tyco Electronics Corporation Harrisburg, PA 17105-3608 #6 STUD, TERMINAL, SPADE	
DIMENSIONS: INCHES 0 PLG ± .001 1 PLG ± .001 2 PLG ± .001 3 PLG ± .010 4 PLG ± .010 ANGLES ± .5°	DIMENSIONS: INCHES 0 PLG ± .001 1 PLG ± .001 2 PLG ± .001 3 PLG ± .010 4 PLG ± .010 ANGLES ± .5°	APPLICATION SPEC: — WEIGHT: —	SIZE: A2 CASE CODE: 00779 DRAWING NO: 40577	RESTRICTED TO: —	CUSTOMER DRAWING SCALE: 8:1 SHEET: 1 of 1 REV: H

AMP 1421-9 REV 31MAY2000

H.L.

40577

A