

4

3

2

1

THIS DRAWING IS UNPUBLISHED. RELEASED FOR PUBLICATION
 © COPYRIGHT - BY TYCO ELECTRONICS CORPORATION. ALL RIGHTS RESERVED.

LOC	DIST	REVISIONS					
		P	LTR	DESCRIPTION	DATE	DWN	APVD
G	14		D	REV PER OG3A-0636-04	13AUG04	JR	TM

AMP WIRE RANGE	Listed FILE E13288	LR7189 Certified
22-16 AWG SOLID OR STRANDED	22-16 AWG SOLID OR STRANDED	22-16 AWG SOLID OR STRANDED

- 1. STAMP AMP 22-18* APPROX AS SHOWN
22-16 TERMINALS ARE STAMPED 22-18 IN
ACCORDANCE WITH MILITARY SPEC MIL-T-7928
COMMERCIAL WIRE RANGE IS 22-16
- 2. WIRE INSUL DIA, 2.67-3.56 [.105-.140]
- 3. TONGUE MATL THK, 0.79±0.05 [.031±.002]
- 4. MATERIAL: BODY - CU PER ASTM B152
SLEEVE - PVC, COLOR - RED

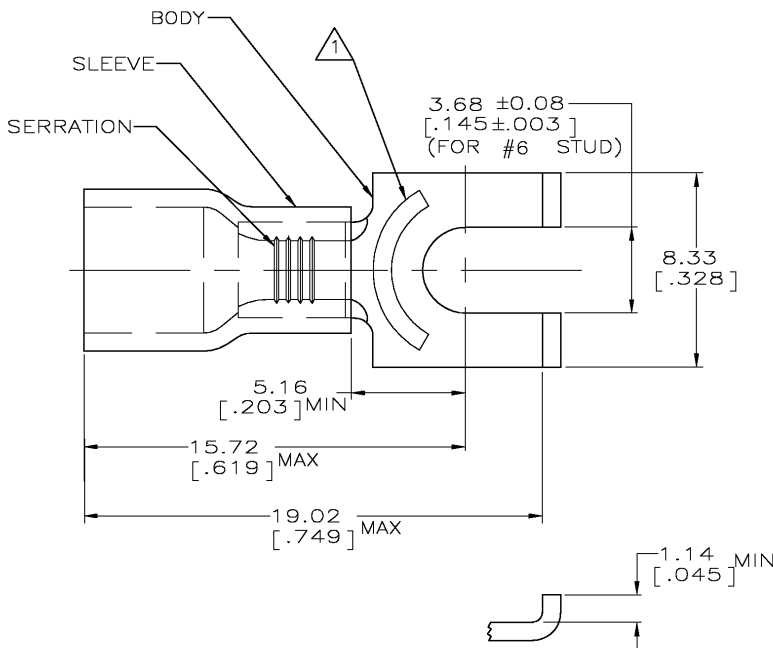

-	-	-
5000	ON TAPE, REEL	2-324560-1
1000	LOOSE PIECE	324560
QTY	PACKAGE TYPE	PART NO

AMP INCORPORATED CUSTOMER SERVICE SYSTEMS		MAX RECOMMENDED OPERATING TEMPERATURE: 105°C	THIS DRAWING IS A CONTROLLED DOCUMENT.		DWN L OLMEDA OSSEP95	Tyco Electronics Corporation Harrisburg, Pa 17105-3608	
FOR ADDITIONAL PRODUCT INFORMATION OR COPIES OF DRAWINGS AND TECHNICAL DOCUMENTS	PRODUCT INFORMATION CENTER 1-800-522-6752	VOLTAGE RATING: 600V MAX (1000V FIXTURE OR SIGN)	DIMENSIONS: mm [INCHES]	TOLERANCES UNLESS OTHERWISE SPECIFIED: 0 PLC ± - 1 PLC ± - 2 PLC ± 0.20 [.008] 3 PLC ± - 4 PLC ± - ANGLES ± -	CHK M ELLIS OSSEP95		NAME G NGO PRODUCT SPEC UL 486A APPLICATION SPEC
FOR APPLICATION	TOOLING ASSISTANCE CENTER 1-800-722-1111	CIRCULAR MIL AREA: 0.26-1.85mm² [509-3260] SOLID OR STRANDED		MATERIAL - 4	APVD G NGO OSSEP95	TERMINAL, SPADE, FLANGED, PLASTI-GRIP, WIRE SIZE: 22-16 AWG	
TOOLING INFORMATION	1-800-722-1111	THIS DRAWING IS A CONTROLLED DOCUMENT FOR AMP INCORPORATED. IT IS SUBJECT TO CHANGE AND THE CONTROLLING ENGINEERING ORGANIZATION SHOULD BE CONTACTED FOR THE LATEST REVISION.		FINISH TIN PER ASTM B545	WEIGHT -	SIZE CAGE CODE DRAWING NO A3 00779 C-324560	
FOR ORDER ENTRY	1-800-526-5142					RESTRICTED TO -	
AMP 1470-19 REV 31MAR2000					CUSTOMER DRAWING		SCALE 6:1 SHEET 1 OF 1 REV D