

4

3

2

1

THIS DRAWING IS UNPUBLISHED. RELEASED FOR PUBLICATION
 © COPYRIGHT - BY TYCO ELECTRONICS CORPORATION. ALL RIGHTS RESERVED.

LOC	DIST	REVISIONS			
P	LTR	DESCRIPTION	DATE	DWN	APVD
G	14	J	REV PER 0G3A-0668-04	24AUG04	JR TM

AMP WIRE RANGE	Listed FILE E13288	LR7189 Certified
12-10 AWG SOLID OR STRANDED	12-10 AWG STRANDED	12-10 AWG SOLID OR STRANDED

- ① STAMP 6S AMP 12-10* APPROX AS SHOWN
2. WIRE INSUL DIA, 3.81-6.35 [.150-.250]
3. TONGUE MATL THK, 1.02±0.05 [.040±.002]
- ④ TIN PLATE PER ASTM B-545
- ⑤ GOLD PLATE PER MIL-G-45204 OVER BRIGHT NICKEL PER QQ-N-290
- ⑥ REPLACED BY 53246-1
- ⑦ MATERIAL: BODY - BRASS PER ASTM B36
SLEEVE - PVC, COLOR - YELLOW

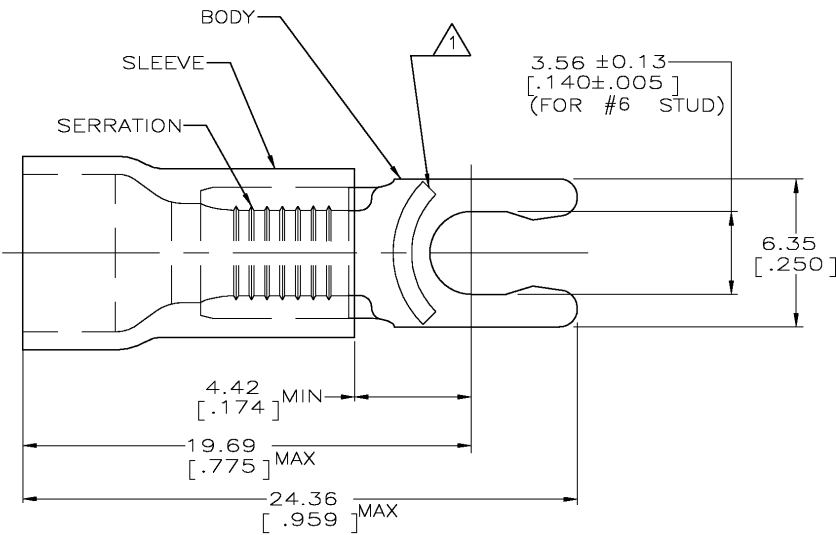

⑥ OBSOLETE	④	50	LOOSE PIECE, BOX	8-53246-2
	④	500	LOOSE PIECE	53246-3
	④	2500	ON TAPE, REEL	53246-2
	④	500	LOOSE PIECE	53246-1
FINISH	QTY	PACKAGE TYPE		PART NO

AMP INCORPORATED CUSTOMER SERVICE SYSTEMS		MAX RECOMMENDED OPERATING TEMPERATURE: 105°C [221°F]	THIS DRAWING IS A CONTROLLED DOCUMENT.		DWN L OLMEDA 26JUN95	Tyco Electronics Corporation Harrisburg, Pa 17105-3608
FOR ADDITIONAL PRODUCT INFORMATION OR COPIES OF DRAWINGS AND TECHNICAL DOCUMENTS	PRODUCT INFORMATION CENTER 1-800-522-6752	VOLTAGE RATING: 600V MAX (1000V FIXTURE OR SIGN)	DIMENSIONS: mm [INCHES]	TOLERANCES UNLESS OTHERWISE SPECIFIED:	CHK M ELLIS 26JUN95	
FOR APPLICATION	TOOLING ASSISTANCE CENTER 1-800-722-1111	CIRCULAR MIL AREA: 2.62-6.64mm² [5,180-13,100] SOLID OR STRANDED		0 PLC ± - 1 PLC ± - 2 PLC ± 0.20 [.008] 3 PLC ± - 4 PLC ± - ANGLES ± -	APVD G NGO 26JUN95	TERMINAL, SPRING SPADE, SHORT, PLASTI-GRIP WIRE SIZE 12-10 AWG
TOOLING INFORMATION	1-800-722-1111	THIS DRAWING IS A CONTROLLED DOCUMENT FOR AMP INCORPORATED. IT IS SUBJECT TO CHANGE AND THE CONTROLLING ENGINEERING ORGANIZATION SHOULD BE CONTACTED FOR THE LATEST REVISION.	MATERIAL ⑦	FINISH SEE TABLE	WEIGHT -	SIZE A3
FOR ORDER ENTRY	1-800-526-5142					CAGE CODE 00779
						DRAWING NO 53246
						RESTRICTED TO -
						CUSTOMER DRAWING
						SCALE 6:1
						SHEET 1 OF 1
						REV J

AMP 1470-19 REV 31MAR2000