

4

3

2

1

THIS DRAWING IS UNPUBLISHED. RELEASED FOR PUBLICATION
 © COPYRIGHT - BY TYCO ELECTRONICS CORPORATION. ALL INTERNATIONAL RIGHTS RESERVED.

LOC	DIST	REVISIONS				
P	LTR	DESCRIPTION	DATE	DWN	APVD	
G	14	E1	REDRAWN PER ECR 09-006116	17MAR09	JR	TM

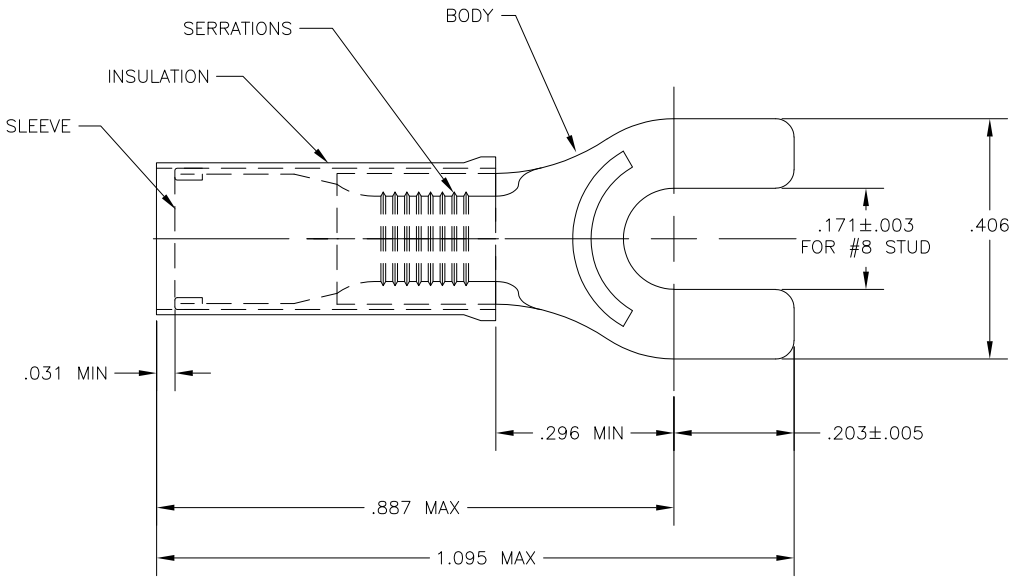

- 1 FOR .150 TO .250 WIRE INSULATION DIA.
- 2 MATERIAL TONGUE THK IS .040±.002

LOOSE PIECE, BOX	INSULATION: NYLON, COLOR YELLOW SLEEVE: COPPER PER ASTM B152 BODY: COPPER PER ASTM B152 TIN PLATE PER ASTM B545	8-35152-2
35152 ON TAPE		2-35152-1
WIRE TERMINAL		35152
DESCRIPTION	MATERIAL	PART NO

THIS DRAWING IS A CONTROLLED DOCUMENT.		DWN		17MAR09		Tyco Electronics Corporation	
DIMENSIONS:		CHK		17MAR09		Harrisburg, PA 17105-3608	
INCHES		TOM MICHIELUTTI		APVD		NAME	
TOLERANCES UNLESS OTHERWISE SPECIFIED:		TOM MICHIELUTTI		17MAR09		TERMINAL, PIDG	
0 PLC ± -		PRODUCT SPEC		-		SPADE, WIRE SIZE 12-10 AWG	
1 PLC ± -		APPLICATION SPEC		-		-	
2 PLC ± -		WEIGHT		-		RESTRICTED TO	
3 PLC ± .008		SIZE		CAGE CODE		DRAWING NO	
4 PLC ± -		A3		00779		35152	
ANGLES ± 5°		MATERIAL		FINISH		SCALE	
SEE TABLE		SEE TABLE		CUSTOMER DRAWING		8:1	
						SHEET 1 OF 1	
						REV E1	