

THIS DRAWING IS UNPUBLISHED. RELEASED FOR PUBLICATION .19
 © COPYRIGHT 19 BY AMP INCORPORATED. ALL INTERNATIONAL RIGHTS RESERVED.

LOC	DIST	P	F	ZONE	LTR	REVISIONS	DESCRIPTION	DATE	APPD
G	14					C	REV & REDRAWN PER 0720-0040-93	3-26-93	APD

METRIC
 DIMENSIONS LISTED IN mm [INCHES]

AMP WIRE RANGE	UL E13288 Listed
16-14 AWG SOLID OR STRANDED	16-14 AWG SOLID OR STRANDED
UL LR7189 Certified	MILITARY P/N AND CLASS
16-14 AWG SOLID OR STRANDED	NOT APPLICABLE

△ STAMP AMP 16-14* APPROX AS SHOWN

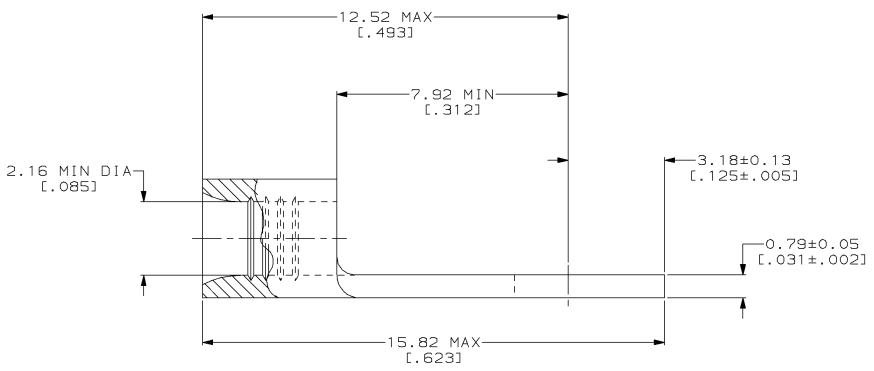
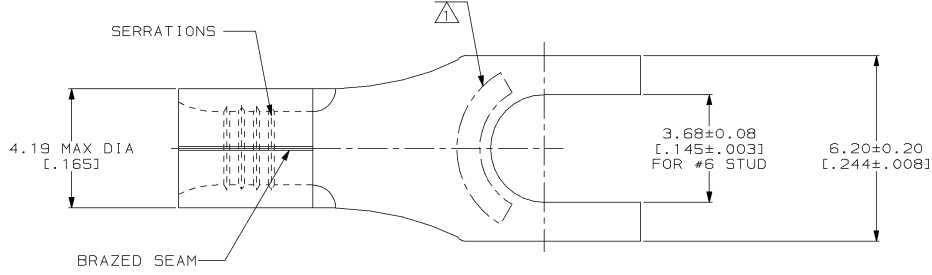

AMP INCORPORATED
 CUSTOMER SERVICE SYSTEMS

MAX RECOMMENDED OPERATING TEMPERATURE:
 170°C MAX

DO NOT SCALE PRINT.
 UNLESS SPECIFIED DIMENSIONS IN mm (INCHES) TOLERANCES ON:
 2 PLC DEC ± -
 3 PLC DEC ± -
 ANGLES ± -

DR 3-26-93
 TA BRINKMAN
 CHK 3-26-93
 DA PATTERSON
 APPD 3-26-93
 DE MILLER

AMP AMP Incorporated
 Harrisburg, PA 17105-3608

FOR ADDITIONAL PRODUCT INFORMATION OR COPIES OF DRAWINGS AND TECHNICAL DOCUMENTS

PRODUCT INFORMATION CENTER
 1-800-522-6752

VOLTAGE RATING:
 NOT APPLICABLE

MATERIAL
 COPPER PER ASTM B-152 ANNEALED

APPD 3-26-93
 JL MECKLEY
 PRODUCT SPEC

NAME
 TERMINAL, SPADE TONGUE, SOLISTRAND™

FOR APPLICATION TOOLING INFORMATION

TOOLING ASSISTANCE CENTER
 1-800-722-1111

WIRE CROSS SECTIONAL AREA RANGE:
 1.04-2.62mm² [2,050-5,180] CIR MILS
 SOLID OR STRANDED

FINISH
 T1N PLATE
 0.00254 [0.00100] MIN THK PER MIL-T-10727

APPLICATION SPEC
 -

SIZE
 00779
 DRAWING NO
 ©-330827

FOR ORDER ENTRY

1-800-526-5142

THIS DRAWING IS A CONTROLLED DOCUMENT FOR AMP INCORPORATED. IT IS SUBJECT TO CHANGE AND THE CONTROLLING ENGINEERING ORGANIZATION SHOULD BE CONTACTED FOR THE LATEST REVISION.

WEIGHT
 -

SCALE 10:1
 SHEET 1 OF 1

AMP 1471-6 REV 3-92
 10_SEP_1993 12:40:39 AMP26463 <U5128A>DEPT1123>DWG1123>U_SOL1STRAND>U_INL_INE

CUSTOMER DRAWING

330827

330827
 PART NO