

DRAWING MADE IN AMERICAN PROJECTION

LOC **G** PRINT QTY **14**

© 1955 BY AMP INCORPORATED. ALL RIGHTS RESERVED. AMP PRODUCTS COVERED BY PATENTS AND/OR PATENTS PENDING.

REVISIONS			
LTR	DESCRIPTION	DATE	APPROVED
E	REV PER G-4732	JT 10/12/88	RJR
F	REV / 0720-0032-93	LO 2/93	ML
G	REV / 0610-0044-98	ME 2-3-99	me/jst

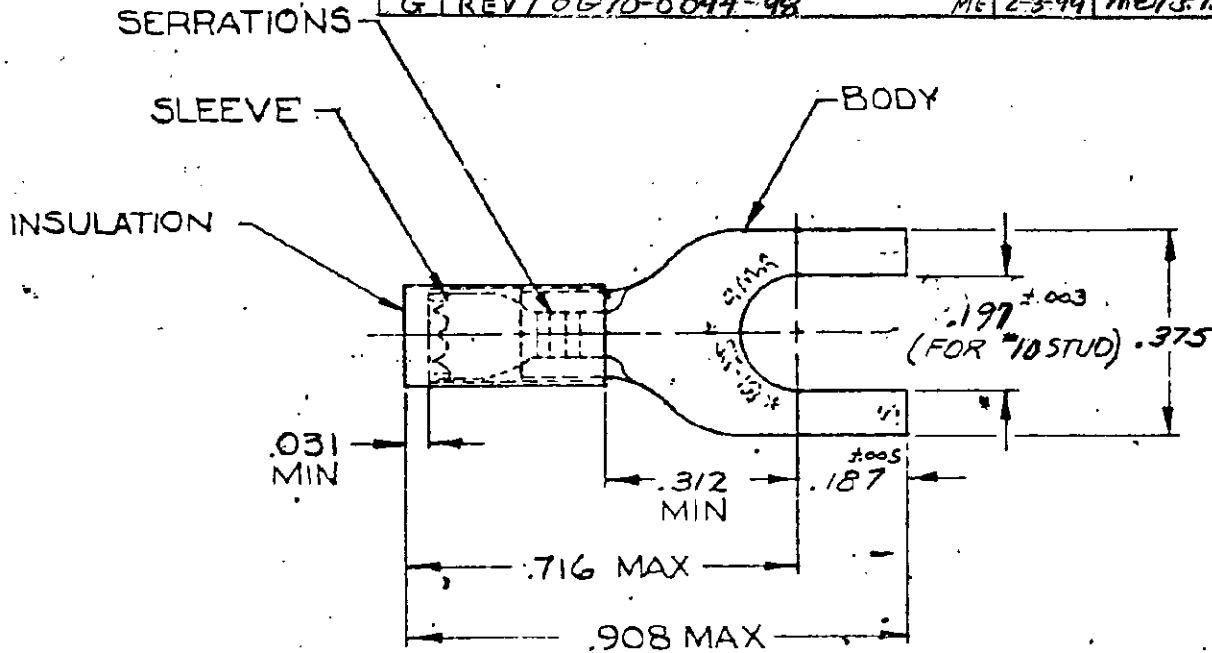

TONGUE MATERIAL THK = .031 ±.002
 FOR .080 TO .125 WIRE INSULATION DIA
 MARKING 22-18 FOR MILITARY
 COMMERCIAL RANGE 22-16

QTY.	DESCRIPTION	PART NO	MATERIAL & FINISH
100	LOOSE Pc, Box	8-32051-1	TIN PL (ASTM B545)
1	32051 ON TAPE	2-32051-1	BODY: COPPER (ASTM B152); SLEEVE: COPPER (ASTM B152)
1	WIRE TERMINAL	32051	TIN PL (ASTM B545) INSULATION: NYLON; COLOR: RED

UNLESS OTHERWISE SPECIFIED DIMENSIONS ARE IN INCHES TOLERANCES ON: DECIMALS ±.008 ANGLES ± 5°	CONTRACT NO.	AMP AMP INCORPORATED HARRISBURG, PENNSYLVANIA
	DR. <i>FM. Enominger</i> 8-11-67	
	CHK. <i>PCY</i> 8-11-67	
	APPRO. <i>Swibel</i> 8-13-69	
MATERIAL SEE TABLE	REL. <i>FM. Enominger</i> 8-14-69	NAME WIRE TERMINAL PIDG™ - SPADE WIRE SIZE: 22-16
	OSGN APPD	SIZE A
	OTHER APPD	CODE IDENT NO. 00779
		NUMBER 32051
SCALE NTS		SHEET 1 OF 1