

4
DRAWING MADE IN THIRD ANGLE PROJECTION

3

2

1 Loc G DIST 14

THIS DRAWING IS UNPUBLISHED. RELEASED FOR PUBLICATION 19
 © COPYRIGHT 19 BY AMP INCORPORATED, HARRISBURG, PA. ALL INTERNATIONAL RIGHTS RESERVED. AMP PRODUCTS MAY BE COVERED BY U.S. AND FOREIGN PATENTS AND/OR PATENTS PENDING.

REVISIONS					
R	F	ZONE	LTR	DESCRIPTION	DATE APPROVED
✓			D	REDRAWN - REVISED PER G-1479, G-1175, P85-0137 & P85-0123	2-13-86 <i>rgm</i>
✓			E	OBSOLETE 1-4 PER G-2393	3/24/87 <i>rgm</i>
✓			F	OBSOLETE 1-3 PER G-3358	4-22-88 <i>rgm</i> / <i>gy</i>
✓			G	REV PER G-4732	JT 7/26/88 <i>rgm</i>
✓			H	OBSOLETE 1-0 PER G-4184	JT 10/6/88 <i>rgm</i>
✓			J	OBS. 1-2 PER G-4216	DES 12-20-89 <i>gy</i>
✓			K	REV/0720-0066-93	4-14-93 TQJ/TML

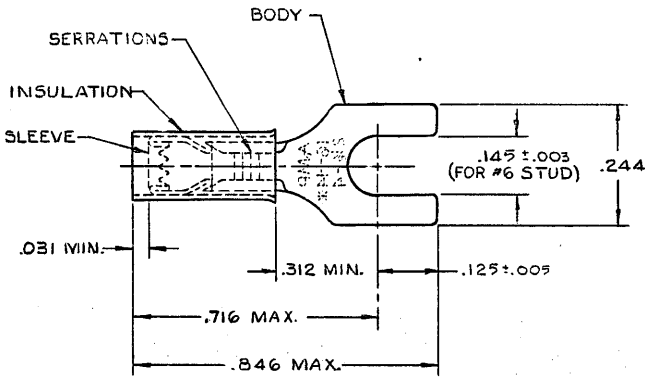

- 1 WIRE INSULATION DIA: SEE TABLE.
- 2 TONGUE MATERIAL THK. .031 ± .002

	.115-.170	100	LOOSE PC. BOX	8-328281-1
OBSOLETE	.115-.170	100	ON TAPE, SM. BOX	1-328281-1
OBSOLETE	.115-.170	1000	ON TAPE, LG. BOX	1-328281-3
OBSOLETE	.115-.170	5000	ON TAPE, REEL	1-328281-2
	.115-.170	5000	ON TAPE, REEL	1-328281-1
OBSOLETE	.115-.170	5000	LOOSE PIECE	1-328281-0
	.115-.170		LOOSE PIECE	328281

WIRE INS. DIA.	QUANTITY	DESCRIPTION	PART NO
UNLESS OTHERWISE SPECIFIED DIMENSIONS ARE IN INCHES. TOLERANCES ON: DECIMALS ± .008 ANGLES ±			
CONTRACT NO		AMP AMP INCORPORATED Harrisburg, Pa.	
DR UTA/RFB 10-4-87		NAME	
MATERIAL: NYLON - BLUE BODY & SLEEVES COPPER (CG-C-576)		TERMINAL P.I.D.G. SPADE WIRE SIZE: 16-14	
FINISH: BODY & SLEEVE TIN PL (MIL-T-10727) .000100 MIN. THK.		SIZE	DRAWING NO
		B 00779	328281
		SCALE	SHEET 1 OF 1
		NTS	

CUSTOMER DRAWING