

4

3

2

1

THIS DRAWING IS UNPUBLISHED. RELEASED FOR PUBLICATION
 © COPYRIGHT - By - ALL RIGHTS RESERVED.

LOC		DIST		REVISIONS			
P	LTR	DESCRIPTION		DATE	DWN	APVD	
	T3	REVISED PER ECO-11-004917		11MAR11	RK	HMR	

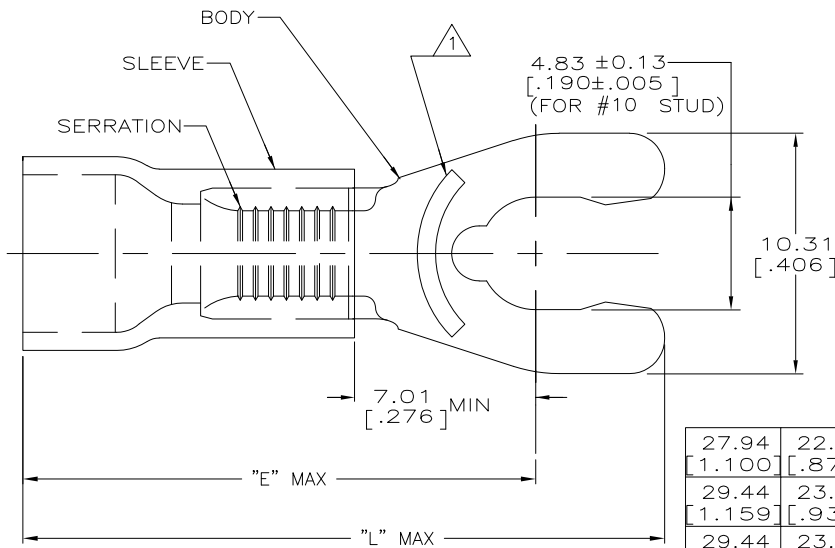

AMP WIRE RANGE	Listed FILE E13288	LR7189 Certified
12-10 AWG SOLID OR STRANDED	12 AWG STRANDED	12-10 AWG SOLID OR STRANDED

- 1. STAMP 10S AMP 12-10*APPROX AS SHOWN
- 2. SEE TABLE FOR WIRE INSUL DIA
- 3. TONGUE MATL THK, 1.02±0.05 [.040±.002]
- 4. MATERIAL: BODY - BRASS PER ASTM B36
SLEEVE - PVC, COLOR - YELLOW

L	E	WIRE INSUL DIA	QTY	PACKAGE TYPE	PART NO
27.94 [1.100]	22.28 [.877]	3.81-6.35 [.150-.250]	50	LOOSE PIECE, BOX	8-52963-2
29.44 [1.159]	23.77 [.936]	6.35-7.62 [.250-.300]	1500	ON TAPE, REEL	52963-5
29.44 [1.159]	23.77 [.936]	6.35-7.62 [.250-.300]	500	LOOSE PIECE	52963-4
27.94 [1.100]	22.28 [.877]	3.81-6.35 [.150-.250]	2500	ON TAPE, REEL	52963-3
27.94 [1.100]	22.28 [.877]	3.81-6.35 [.150-.250]	500	LOOSE PIECE	52963-2
27.94 [1.100]	22.28 [.877]	2.67-5.08 [.105-.200]	2500	ON TAPE, REEL	52963-1
27.94 [1.100]	22.28 [.877]	2.67-5.08 [.105-.200]	500	LOOSE PIECE	52963

AMP INCORPORATED
CUSTOMER SERVICE SYSTEMS

FOR ADDITIONAL PRODUCT INFORMATION OR COPIES OF DRAWINGS AND TECHNICAL DOCUMENTS
 PRODUCT INFORMATION CENTER
 1-800-522-6752

FOR APPLICATION TOOLING ASSISTANCE CENTER
 TOOLING INFORMATION
 1-800-722-1111

FOR ORDER ENTRY
 1-800-526-5142

MAX RECOMMENDED OPERATING TEMPERATURE:
 105°C [221°F]

VOLTAGE RATING:
 600V MAX
 (1000V FIXTURE OR SIGN)

CIRCULAR MIL AREA:
 2.62-6.64mm² [5,180-13,100]
 SOLID OR STRANDED

THIS DRAWING IS A CONTROLLED DOCUMENT FOR AMP INCORPORATED. IT IS SUBJECT TO CHANGE AND THE CONTROLLING ENGINEERING ORGANIZATION SHOULD BE CONTACTED FOR THE LATEST REVISION.

THIS DRAWING IS A CONTROLLED DOCUMENT.

DIMENSIONS:
 mm [INCHES]

TOLERANCES UNLESS OTHERWISE SPECIFIED:

0 PLC	± -
1 PLC	± -
2 PLC	± 0.20 [008]
3 PLC	± -
4 PLC	± -
ANGLES	± -

MATERIAL: FINISH: TIN PER ASTM B545

DWN: L OLMEDA 26JUN95
 CHK: M ELLIS 26JUN95
 APVD: G NGO 26JUN95

TE TE Connectivity

NAME: UL 486A
 PRODUCT SPEC: UL 486A
 APPLICATION SPEC: -

TERMINAL, SPRING SPADE,
 SHORT, PLASTI-GRIP
 WIRE SIZE: 12-10 AWG

SIZE: A3 CAGE CODE: 00779 DRAWING NO: C-52963 RESTRICTED TO: -

WEIGHT: -

CUSTOMER DRAWING SCALE: 6:1 SHEET: 1 OF 1 REV: T3