

4

3

2

1

THIS DRAWING IS UNPUBLISHED. RELEASED FOR PUBLICATION  
 © COPYRIGHT - By - ALL RIGHTS RESERVED.

LOC	DIST	REVISIONS			
P	LTR	DESCRIPTION	DATE	DWN	APVD
S1		REVISED PER ECO-11-004917	11MAR11	RK	HMR

<b>AMP</b> WIRE RANGE	Listed FILE E13288	LR7189 Certified
12-10 AWG SOLID OR STRANDED	12 AWG STRANDED	12-10 AWG SOLID OR STRANDED

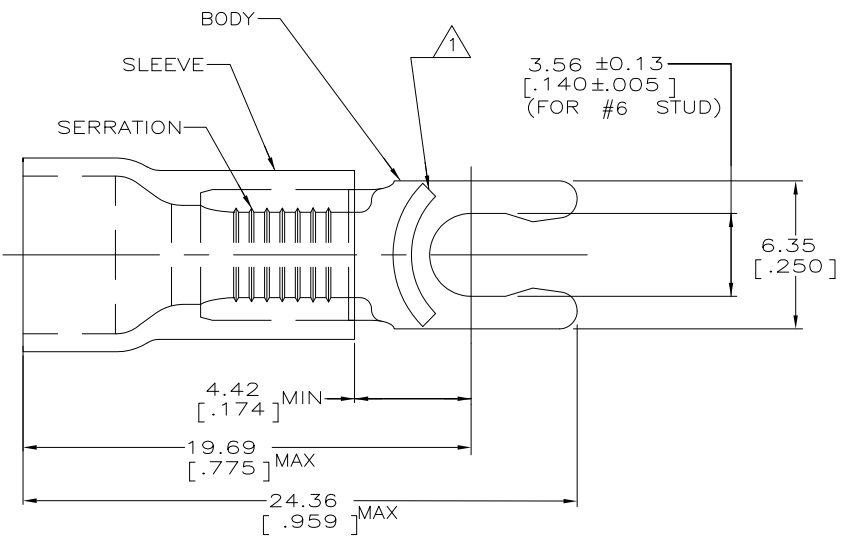

- ① STAMP 6SAMP 12-10\* APPROX AS SHOWN
- 2. WIRE INSUL DIA, 2.67-5.08 [.105-.200]
- 3. TONGUE MATL THK, 1.02±0.05 [.040±.002]
- ④ MATERIAL: BODY - BRASS PER ASTM B36  
SLEEVE - PVC, COLOR - YELLOW

50	LOOSE PIECE, BOX	8-52961-2
2500	ON TAPE, REEL	52961-1
500	LOOSE PIECE	52961
QTY	PACKAGE TYPE	PART NO

AMP INCORPORATED CUSTOMER SERVICE SYSTEMS		MAX RECOMMENDED OPERATING TEMPERATURE: 105°C [221°F]	THIS DRAWING IS A CONTROLLED DOCUMENT.		DWN L OLMEDA 26JUN95	TE Connectivity	
FOR ADDITIONAL PRODUCT INFORMATION OR COPIES OF DRAWINGS AND TECHNICAL DOCUMENTS	PRODUCT INFORMATION CENTER 1-800-522-6752	VOLTAGE RATING: 600V MAX (1000V FIXTURE OR SIGN)	DIMENSIONS: mm[INCHES]	TOLERANCES UNLESS OTHERWISE SPECIFIED:	CHK M ELLIS 26JUN95	NAME G NGO 26JUN95	
FOR APPLICATION	TOOLING ASSISTANCE CENTER 1-800-722-1111	CIRCULAR MIL AREA: 2.62-6.64mm²[5,180-13,100] SOLID OR STRANDED		0 PLC ± - 1 PLC ± - 2 PLC ±0.20 [.008] 3 PLC ± - 4 PLC ± - ANGLES ± -	APVD G NGO 26JUN95	PRODUCT SPEC UL 486A	
TOOLING INFORMATION	1-800-722-1111		MATERIAL	FINISH TIN PER ASTM B545	APPLICATION SPEC	SIZE A3	CAGE CODE 00779
FOR ORDER ENTRY	1-800-526-5142	THIS DRAWING IS A CONTROLLED DOCUMENT FOR AMP INCORPORATED. IT IS SUBJECT TO CHANGE AND THE CONTROLLING ENGINEERING ORGANIZATION SHOULD BE CONTACTED FOR THE LATEST REVISION.			WEIGHT	DRAWING NO C-52961	RESTRICTED TO
					CUSTOMER DRAWING	SCALE 6:1	SHEET 1 of 1
						REV S1	

1470-19 (3/11)