

4

3

2

1

THIS DRAWING IS UNPUBLISHED. RELEASED FOR PUBLICATION
 © COPYRIGHT - By - ALL RIGHTS RESERVED.

LOC	DIST	REVISIONS			
P	LTR	DESCRIPTION	DATE	DWN	APVD
	P1	REVISED PER ECO-11-004917	11MAR11	RK	HMR

AMP WIRE RANGE	Listed FILE E13288	LR7189 Certified
22-16 AWG SOLID OR STRANDED	22-16 AWG SOLID OR STRANDED	22-16 AWG SOLID OR STRANDED

△ STAMP 10S AMP 22-18* APPROX AS SHOWN
 22-16 TERMINALS ARE STAMPED 22-18 IN
 ACCORDANCE WITH MILITARY SPEC MIL-T-7928
 COMMERCIAL WIRE RANGE IS 22-16

2. SEE TABLE FOR WIRE INSUL DIA

3. TONGUE MATL THK, 0.79±0.05 [.031±.002]

△ 4 MATERIAL: BODY - BRASS PER ASTM B36
 SLEEVE - PVC, COLOR - RED

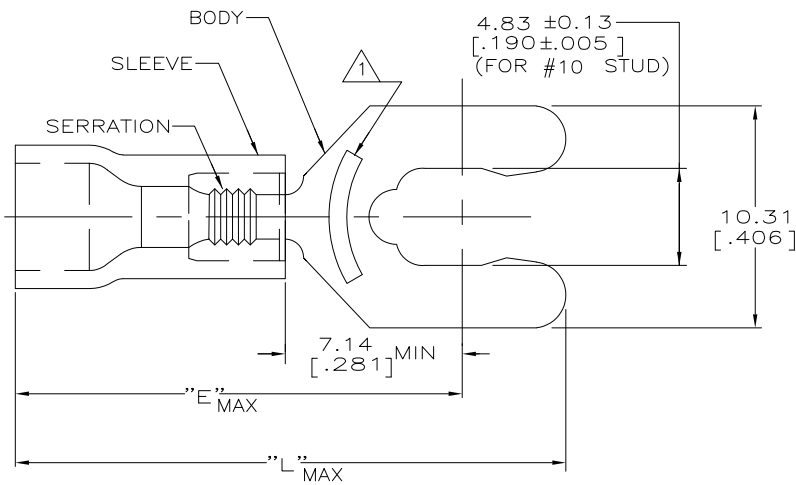

23.37 [.920]	17.70 [.697]	2.67-3.56 [.105-.140]	100	LOOSE PIECE, BOX	8-52951-1
24.61 [.969]	18.95 [.746]	3.81-5.08 [.150-.200]	2500	ON TAPE, REEL	52951-3
23.37 [.920]	17.70 [.697]	2.67-3.56 [.105-.140]	5000	ON TAPE, REEL	52951-1
23.37 [.920]	17.70 [.697]	2.67-3.56 [.105-.140]	1000	LOOSE PIECE	52951
L	E	WIRE INSUL DIA	QTY	PACKAGE TYPE	PART NO

AMP INCORPORATED CUSTOMER SERVICE SYSTEMS		MAX RECOMMENDED OPERATING TEMPERATURE: 105°C [221°F]	THIS DRAWING IS A CONTROLLED DOCUMENT.		DWN L OLMEDA 26JUN95	TE Connectivity			
FOR ADDITIONAL PRODUCT INFORMATION OR COPIES OF DRAWINGS AND TECHNICAL DOCUMENTS	PRODUCT INFORMATION CENTER 1-800-522-6752	VOLTAGE RATING: 600V MAX (1000V FIXTURE OR SIGN)	DIMENSIONS: mm[INCHES]	TOLERANCES UNLESS OTHERWISE SPECIFIED:	CHK M ELLIS 26JUN95	NAME			
FOR APPLICATION	TOOLING ASSISTANCE CENTER 1-800-722-1111	CIRCULAR MIL AREA: 0.26-1.65mm² [509-3260] SOLID OR STRANDED		0 PLC ± - 1 PLC ± - 2 PLC ± 0.20 [008] 3 PLC ± - 4 PLC ± - ANGLES ± -	APVD G NGO 26JUN95	PRODUCT SPEC UL 486A			
TOOLING INFORMATION	1-800-722-1111	THIS DRAWING IS A CONTROLLED DOCUMENT FOR AMP INCORPORATED. IT IS SUBJECT TO CHANGE AND THE CONTROLLING ENGINEERING ORGANIZATION SHOULD BE CONTACTED FOR THE LATEST REVISION.	MATERIAL	FINISH TIN PER ASTM B545	APPLICATION SPEC	SIZE A3	CAGE CODE 00779	DRAWING NO C-52951	RESTRICTED TO
FOR ORDER ENTRY	1-800-526-5142				WEIGHT				
					CUSTOMER DRAWING	SCALE 6:1	SHEET 1 of 1	REV P1	

1470-19 (3/11)