

4

3

2

1

THIS DRAWING IS UNPUBLISHED. RELEASED FOR PUBLICATION
 © COPYRIGHT - By - ALL RIGHTS RESERVED.

LOC	DIST	REVISIONS			
P	LTR	DESCRIPTION	DATE	DWN	APVD
G	14				
	G2	REVISED PER ECO-11-004820	11MAR11	RK	HMR

AMP WIRE RANGE	Listed FILE E13288	LR7189 Certified
22-16 AWG SOLID OR STRANDED	22-16 AWG SOLID OR STRANDED	22-16 AWG SOLID OR STRANDED

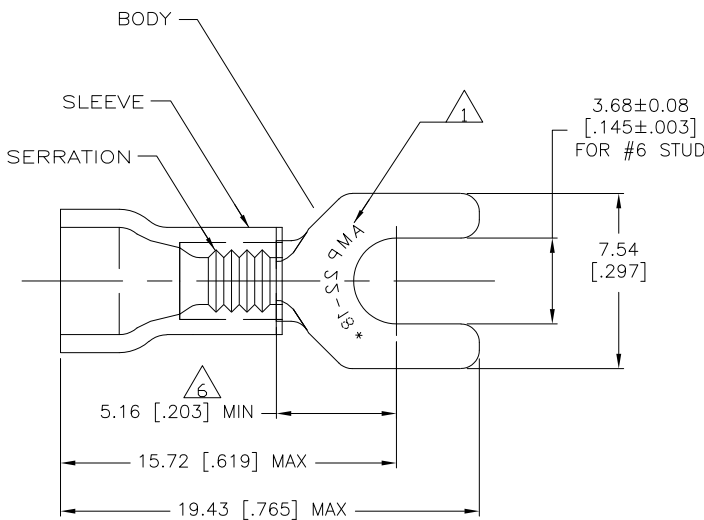

- 1. STAMP AMP 22-18* APPROX AS SHOWN
22-16 TERMINALS ARE STAMPED 22-18 IN
ACCORDANCE WITH MILITARY SPEC MIL-T-7928
COMMERCIAL WIRE RANGE IS 22-16
- 2. WIRE INSUL DIA, 2.67 TO 3.56 [.105 TO .140]
- 3. TONGUE MATL THK, 0.79 ± 0.05 [.031 ± .002]
- 4. SUPERSEDED BY 8-320665-5
- 5. MATERIAL: BODY - CU PER ASTM B152
SLEEVE - PVC, COLOR - RED
- 6. APPLIES FROM THE METAL EDGE OF BARREL
TO THE CENTER OF THE STUD.

50	LOOSE PIECE, BAG	8-320665-5
5	LOOSE PIECE, BLS	8-320665-4
100	LOOSE PIECE, BOX	8-320665-1
5000	ON TAPE, REEL	2-320665-1
1000	LOOSE PIECE	320665
QTY	PACKAGE TYPE	PART NO

AMP INCORPORATED
CUSTOMER SERVICE SYSTEMS

FOR ADDITIONAL PRODUCT INFORMATION OR COPIES OF DRAWINGS AND TECHNICAL DOCUMENTS
 PRODUCT INFORMATION CENTER
 1-800-522-6752

FOR APPLICATION TOOLING ASSISTANCE CENTER
 TOOLING INFORMATION
 1-800-722-1111

FOR ORDER ENTRY
 1-800-526-5142

MAX RECOMMENDED OPERATING TEMPERATURE:
 105°C

VOLTAGE RATING:
 600V MAX
 (1000V FIXTURE OR SIGN)

CIRCULAR MIL AREA:
 0.26-1.65mm²[509-3260]
 SOLID OR STRANDED

THIS DRAWING IS A CONTROLLED DOCUMENT FOR AMP INCORPORATED. IT IS SUBJECT TO CHANGE AND THE CONTROLLING ENGINEERING ORGANIZATION SHOULD BE CONTACTED FOR THE LATEST REVISION.

THIS DRAWING IS A CONTROLLED DOCUMENT.

DIMENSIONS:
 mm [INCHES]

TOLEANCES UNLESS OTHERWISE SPECIFIED:
 0 PLC ± -
 1 PLC ± -
 2 PLC ± 0.20 [.008]
 3 PLC ± -
 4 PLC ± -
 ANGLES ± -

MATERIAL: - 5

FINISH: -

DWN: G VINSON 28NOV94
 CHK: M ELLIS 28NOV94
 APVD: G NGO 28NOV94

TE Connectivity

NAME: M ELLIS
 PRODUCT SPEC: UL 486A
 APPLICATION SPEC: -

TERMINAL, SPADE,
 PLASTI-GRIP
 WIRE SIZE : 22-16 AWG

SIZE: A3 CAGE CODE: 00779 DRAWING NO: 320665 RESTRICTED TO: -

WEIGHT: -

CUSTOMER DRAWING SCALE: 6:1 SHEET: 1 OF 1 REV: G2