

4

3

2

1

THIS DRAWING IS UNPUBLISHED. RELEASED FOR PUBLICATION
 © COPYRIGHT - By - ALL RIGHTS RESERVED.

LOC	DIST	REVISIONS			
P	LTR	DESCRIPTION	DATE	DWN	APVD
G	14	L1	REVISED PER ECO-11-005027	12MAR11	RK HMR

AMP WIRE RANGE	Listed FILE E13288	LR7189 Certified
22-16 AWG SOLID OR STRANDED	22-16 AWG SOLID OR STRANDED	22-16 AWG SOLID OR STRANDED

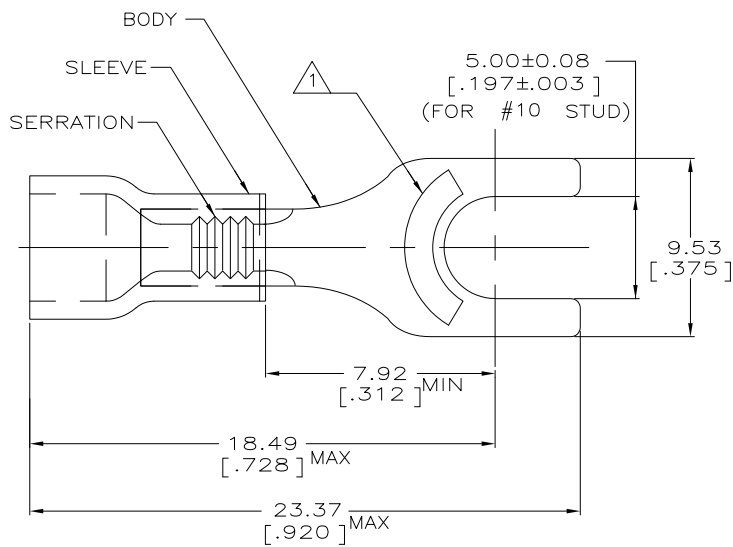

- ① STAMP AMP 22-18* APPROX AS SHOWN
 22-16 TERMINALS ARE STAMPED 22-18 IN
 ACCORDANCE WITH MILITARY SPEC MIL-T-7928
 COMMERCIAL WIRE RANGE IS 22-16
2. WIRE INSUL DIA, 2.67 - 3.56 [.105-.140]
3. TONGUE MATL THK, 0.79±0.05 [.031±.002]
- ④ REPLACED BY 2-34156-1
- ⑤ MATERIAL: BODY - CU PER ASTM B152
 SLEEVE - PVC, COLOR - RED

50	LOOSE PIECE, BAG	8-34156-5
5	LOOSE PIECE, BLS	8-34156-4
100	LOOSE PIECE, BOX	8-34156-1
5000	ON TAPE, REEL	2-34156-4
5000	ON TAPE, REEL	2-34156-1
1000	LOOSE PIECE	34156
QTY	PACKAGE TYPE	PART NO

④ OBSOLETE

AMP INCORPORATED CUSTOMER SERVICE SYSTEMS		MAX RECOMMENDED OPERATING TEMPERATURE: 105°C [221°F]	THIS DRAWING IS A CONTROLLED DOCUMENT.		DWN G VINSON 07NOV94	TE Connectivity	
FOR ADDITIONAL PRODUCT INFORMATION OR COPIES OF DRAWINGS AND TECHNICAL DOCUMENTS	PRODUCT INFORMATION CENTER 1-800-522-6752	VOLTAGE RATING: 600V MAX (1000V FIXTURE OR SIGN)	DIMENSIONS: mm[INCHES]	TOLERANCES UNLESS OTHERWISE SPECIFIED:	CHK M ELLIS 07NOV94	NAME	
FOR APPLICATION	TOOLING ASSISTANCE CENTER 1-800-722-1111	CIRCULAR MIL AREA: 0.26-1.65mm²[509-3260] SOLID OR STRANDED		0 PLC ± - 1 PLC ± - 2 PLC ± 0.20 [0.008] 3 PLC ± - 4 PLC ± - ANGLES ± -	APVD G NGO 07NOV94	PRODUCT SPEC UL 486A	
TOOLING INFORMATION	1-800-722-1111	THIS DRAWING IS A CONTROLLED DOCUMENT FOR AMP INCORPORATED. IT IS SUBJECT TO CHANGE AND THE CONTROLLING ENGINEERING ORGANIZATION SHOULD BE CONTACTED FOR THE LATEST REVISION.	MATERIAL	FINISH	APPLICATION SPEC	SIZE	CAGE CODE
FOR ORDER ENTRY	1-800-526-5142				WEIGHT	A3	00779
					CUSTOMER DRAWING	DRAWING NO	34156
						RESTRICTED TO	
						SCALE	6:1
						SHEET	1 OF 1
						REV	L1

1470-19 (3/11)