

4

3

2

1

THIS DRAWING IS UNPUBLISHED. RELEASED FOR PUBLICATION  
 © COPYRIGHT - BY TYCO ELECTRONICS CORPORATION. ALL RIGHTS RESERVED.

| LOC | DIST | REVISIONS   |                      |         |       |
|-----|------|-------------|----------------------|---------|-------|
| P   | LTR  | DESCRIPTION | DATE                 | DWN     | APVD  |
| G   | 14   | H           | REV PER 0G3A-0832-04 | 27JAN05 | JR TM |

|                                |                                |                                |
|--------------------------------|--------------------------------|--------------------------------|
| <b>AMP</b><br>WIRE RANGE       | Listed                         | LR7189<br>Certified            |
| 16-14 AWG<br>SOLID OR STRANDED | 16-14 AWG<br>SOLID OR STRANDED | 16-14 AWG<br>SOLID OR STRANDED |

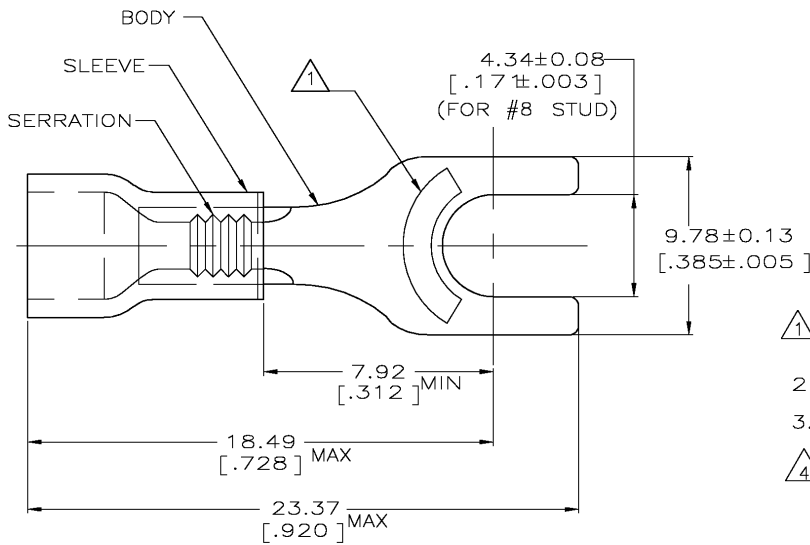

- 1. STAMP AMP16-14\* LOCATE APPROX AS SHOWN
- 2. WIRE INSUL DIA, 3.00-4.90 [.118-.193]
- 3. TONGUE MATL THK, 0.79 ± 0.05 [.031 ± .002]
- 4. MATERIAL: BODY - CU PER ASTM B152  
SLEEVE - PVC, COLOR - BLUE

|      |                  |           |
|------|------------------|-----------|
| 5    | LOOSE PIECE, BLS | 8-34166-4 |
| 100  | LOOSE PIECE, BOX | 8-34166-1 |
| 5000 | ON TAPE, REEL    | 2-34166-1 |
| 1000 | LOOSE PIECE      | 34166     |
| QTY  | PACKAGE TYPE     | PART NO   |

|  |  |   |  |   |                         |   |
|--|--|---|--|---|-------------------------|---|
| <b>AMP INCORPORATED<br/>CUSTOMER SERVICE SYSTEMS</b>                             |  | MAX RECOMMENDED OPERATING TEMPERATURE:<br>105°C [221° F]  | THIS DRAWING IS A CONTROLLED DOCUMENT. |   | DWN<br>L OLMEDA 03NOV84 | Tyco Electronics Corporation<br>Harrisburg, Pa 17105-3608 |
| FOR ADDITIONAL PRODUCT INFORMATION OR COPIES OF DRAWINGS AND TECHNICAL DOCUMENTS | PRODUCT INFORMATION CENTER<br>1-800-522-6752 | VOLTAGE RATING:<br>600V MAX<br>(1000V FIXTURE OR SIGN)  | DIMENSIONS:<br>mm [INCHES]             | TOLERANCES UNLESS OTHERWISE SPECIFIED:<br>0 PLC ± -<br>1 PLC ± -<br>2 PLC ± 0.20 [.008]<br>3 PLC ± -<br>4 PLC ± -<br>ANGLES ± - | CHK<br>M ELLIS 03NOV84  |   |
| FOR APPLICATION  | TOOLING ASSISTANCE CENTER<br>1-800-722-1111  | CIRCULAR MIL AREA:<br>1.04-2.62mm² [2,050-5,180]<br>SOLID OR STRANDED   |  | FINISH<br>-   | APVD<br>G NGO 03NOV84   | PRODUCT SPEC<br>UL486A                                    |
| TOOLING INFORMATION  | 1-800-722-1111                               |   | MATERIAL<br>-                          |   | APPLICATION SPEC<br>-   | SIZE CAGE CODE DRAWING NO<br>A3 00779 C-34166             |
| FOR ORDER ENTRY  | 1-800-526-5142                               | THIS DRAWING IS A CONTROLLED DOCUMENT FOR AMP INCORPORATED. IT IS SUBJECT TO CHANGE AND THE CONTROLLING ENGINEERING ORGANIZATION SHOULD BE CONTACTED FOR THE LATEST REVISION. |  |   | WEIGHT<br>-             | RESTRICTED TO<br>-  |
|  |  |   |  |   | CUSTOMER DRAWING        | SCALE 6:1 SHEET 1 OF 1 REV H                              |

AMP 1470-19 REV 31MAR2000