

4

3

2

1

THIS DRAWING IS UNPUBLISHED. RELEASED FOR PUBLICATION
 © COPYRIGHT - BY TYCO ELECTRONICS CORPORATION. ALL INTERNATIONAL RIGHTS RESERVED.

LOC	DIST	REVISIONS			
P	LTR	DESCRIPTION	DATE	DWN	APVD
G	14				
		C	REV PER ECR 10-005107	08MAR10	JR TM

① STAMP 8S AMP 22-18* APPROX AS SHOWN
 22-16 TERMINALS ARE STAMPED 22-18 IN
 ACCORDANCE WITH MILITARY SPEC MIL-T-7928
 COMMERCIAL WIRE RANGE IS 22-16

2 WIRE INSULATION DIA: 2.67-3.56 [.105-.140]

3 TONGUE MATERIAL THK: 0.79 ± 0.05 [.031 ± 0.002]

④ BODY - PHOS BRONZE PER ASTM B103
 SLEEVE - COPPER PER ASTM B152
 INSULATION - NYLON

⑤ BODY & SLEEVE - TIN PL PER ASTM B545
 INSULATION - COLOR RED

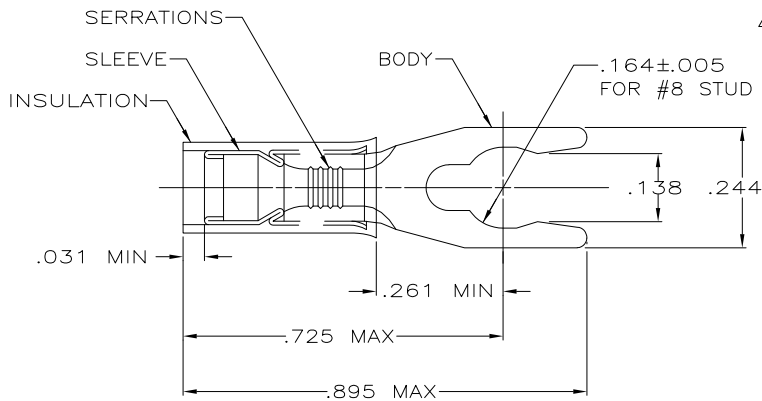

5000	ON TAPE, REEL	55768-1
QUANTITY	PACKAGE TYPE	PART NO.

THIS DRAWING IS A CONTROLLED DOCUMENT.		DWN	MS FEHER	8/31/88	Tyco Electronics Corporation	
DIMENSIONS:		CHK	JR RUTH	9/1/88	Harrisburg, PA 17105-3608	
INCHES		APVD	G YETTER	9/1/88	NAME	
TOLERANCES UNLESS OTHERWISE SPECIFIED:		PRODUCT SPEC		TERMINAL, SPRING SPADE, PIDG, WIRE SIZE: 22-16		
0 PLC	± -	APPLICATION SPEC		RESTRICTED TO		
1 PLC	± -	WEIGHT		SIZE	CAGE CODE	DRAWING NO
2 PLC	± -	MATERIAL		A3	00779	C-55768
3 PLC	± .008	FINISH		CUSTOMER DRAWING		
4 PLC	± -	MATERIAL		SCALE 5:1 SHEET 1 OF 1 REV C		
4 ANGLES	± -	FINISH		SCALE 5:1 SHEET 1 OF 1 REV C		

1470-19 (1/08)