

THIS DRAWING IS UNPUBLISHED. RELEASED FOR PUBLICATION  
 © COPYRIGHT - By - ALL RIGHTS RESERVED.

LOC	DIST	REVISIONS			
P	LTR	DESCRIPTION	DATE	DWN	APVD
G	14	REVISED PER ECO-11-004917	11MAR11	RK	HMR

- 1 WIRE INSULATION DIA, SEE TABLE "A"
- 2 TONGUE MATL THK, 0.789±0.05 [.031±.002].
- 3 BODY: PHOS BRONZE PER ASTM B103  
INSULATION: NYLON  
SLEEVE: COPPER PER ASTM B152
- 4 BODY: TIN PLATE PER ASTM B545  
SLEEVE: TIN PLATE PER ASTM B545  
INSULATION: COLOR-BLUE

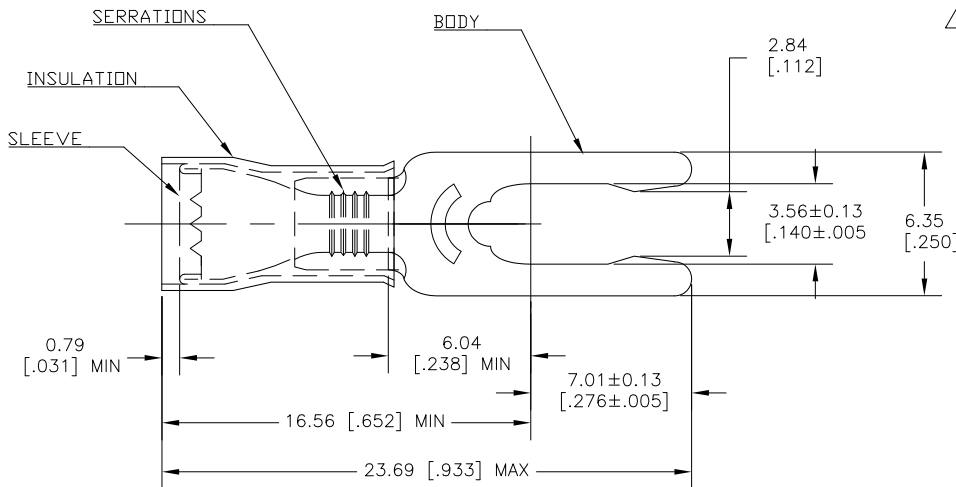

.115-.170	100	LOOSE PIECE, BOX	9-52420-1
.105-.150	100	LOOSE PIECE, BOX	8-52420-1
.115-.170	--	ON TAPE	52420-3
.105-.150	--	ON TAPE	52420-2
.115-.170	--	LOOSE PIECE	52420-1
.105-.150	--	LOOSE PIECE	52420
DIM "A"	QTY	PACKAGE TYPE	PART NO

THIS DRAWING IS A CONTROLLED DOCUMENT.		DWN jr_ruth 28JUN10	TE Connectivity	
DIMENSIONS: mm(INCHES)		CHK TOM MICHIELUTTI 14MAY10		
TOLERANCES UNLESS OTHERWISE SPECIFIED:		APVD TOM MICHIELUTTI 14MAY10	NAME TERMINAL, PIDG, SPRING SPADE, WIRE SIZE: 16-14	
0 PLC ± -	1 PLC ± -	PRODUCT SPEC	SIZE CAGE CODE DRAWING NO	
2 PLC ± 0.2 [.008]	3 PLC ± -	APPLICATION SPEC	A3 00779 C=52420	
4 PLC ± -	ANGLES ± 5°	WEIGHT	RESTRICTED TO	
MATERIAL	FINISH	CUSTOMER DRAWING	SCALE 6:1 SHEET 1 of 1 REV G2	