

4

3

2

1

THIS DRAWING IS UNPUBLISHED. RELEASED FOR PUBLICATION
 © COPYRIGHT - BY TYCO ELECTRONICS CORPORATION. ALL RIGHTS RESERVED.

LOC	DIST	REVISIONS				
P	LTR	DESCRIPTION	DATE	DWN	APVD	
G	14	L1	REV PER ECR 10-009503	04MAY10	JR	TM

AMP WIRE RANGE	Listed FILE E13288	LR7189 Certified
22-16 AWG SOLID OR STRANDED	22-16 AWG SOLID OR STRANDED	22-16 AWG SOLID OR STRANDED

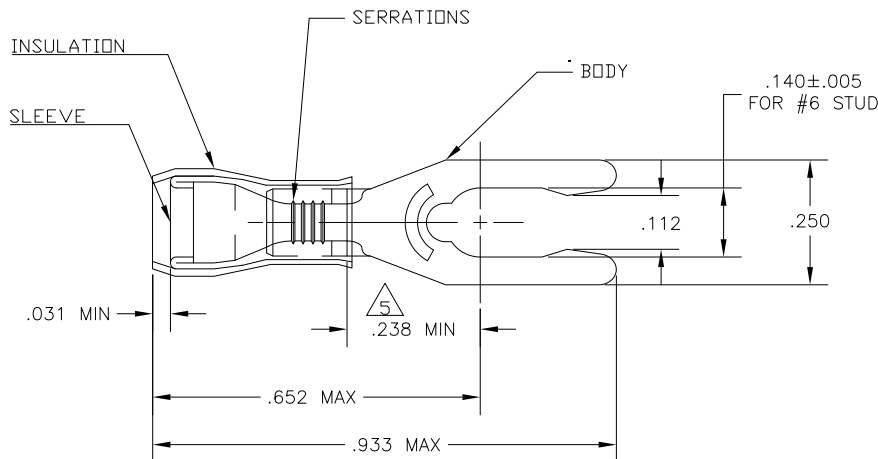

- 1 STAMP AMP 22-18* APPROX AS SHOWN
 22-16 TERMINALS ARE STAMPED 22-18 IN
 ACCORDANCE WITH MILITARY SPEC MIL-T-7928
 COMMERCIAL WIRE RANGE IS 22-16
- 2 WIRE INSULATION DIA: DIM "A", SEE TABLE
- 3 TONGUE MATERIAL THK: .031±.002
- 4 MATERIAL: BODY - PHOS BRONZE PER ASTM B103
 TIN PLATE PER ASTM B545
 SLEEVE - CU PER ASTM B152
 TIN PLATE PER ASTM B545
 INSULATION - NYLON, COLOR - RED
- 5 APPLIES FROM THE METAL EDGE OF BARREL TO
 CENTERLINE OF STUD.

.080-.125	100	52409 IN BOX	8-52409-1
.105-.140	5000	52409-2 ON TAPE, REEL	52409-3
.105-.140	1	LOOSE PIECE	52409-2
.080-.125	5000	52409 ON TAPE, REEL	52409-1
.080-.125	1	LOOSE PIECE	52409
"A"	QTY	PACKAGING TYPE	PART NO.

CUSTOMER SERVICE SYSTEMS

FOR ADDITIONAL
 PRODUCT INFORMATION OR
 COPIES OF DRAWINGS
 AND TECHNICAL DOCUMENTS

PRODUCT INFORMATION CENTER
 1-800-522-6752

FOR APPLICATION
 TOOLING INFORMATION

TOOLING ASSISTANCE CENTER
 1-800-722-1111

FOR ORDER ENTRY
 1-800-526-5142

THIS DRAWING IS A CONTROLLED DOCUMENT FOR
 AMP INCORPORATED. IT IS SUBJECT TO CHANGE
 AND THE CONTROLLING ENGINEERING ORGANIZATION
 SHOULD BE CONTACTED FOR THE LATEST REVISION.

MAX RECOMMENDED OPERATING
 TEMPERATURE:
 105°C [221°F]

VOLTAGE RATING:
 300 V MAX

CIRCULAR MIL AREA:
 0.26-1.65mm² [509-3260]
 SOLID OR STRANDED

THIS DRAWING IS A CONTROLLED DOCUMENT.

DIMENSIONS:

INCHES



MATERIAL

- 4

TOLERANCES UNLESS
 OTHERWISE SPECIFIED:

0 PLC	± -
1 PLC	± -
2 PLC	± .008
3 PLC	± -
4 PLC	± -
ANGLES	± -

FINISH

TIN PL PER ASTM B-545

DWN 10DEC09

JR RUTH

CHK

TOM MICHIELUTTI

APVD 10DEC09

TOM MICHIELUTTI

NAME

PRODUCT SPEC

108-1034

APPLICATION SPEC

NOT AVAILABLE

WEIGHT

CUSTOMER DRAWING



Tyco Electronics Corporation
 Harrisburg, PA 17105-3608

NAME

TOM MICHIELUTTI

PRODUCT SPEC

108-1034

APPLICATION SPEC

NOT AVAILABLE

WEIGHT

CUSTOMER DRAWING

SCALE

4:1

SHEET

1 OF 1

REV

L1