

4

3

2

1

THIS DRAWING IS UNPUBLISHED. RELEASED FOR PUBLICATION  
 © COPYRIGHT - By - ALL RIGHTS RESERVED.

LOC	DIST	REVISIONS			
P	LTR	DESCRIPTION	DATE	DWN	APVD
G	14				
	H2	REVISED PER ECO-11-004820	11MAR11	RK	HMR

- 1 WIRE INSULATION DIA, SEE TABLE "A"
- 2 TONGUE MATL THK, 0.789±0.05 [0.031±.002].
- ③ BODY: PHOS BRONZE PER ASTM B103  
INSULATION: NYLON  
SLEEVE: COPPER PER ASTM B152
- ④ BODY: TIN PLATE PER ASTM B545  
SLEEVE: TIN PLATE PER ASTM B545  
INSULATION: COLOR-BLUE

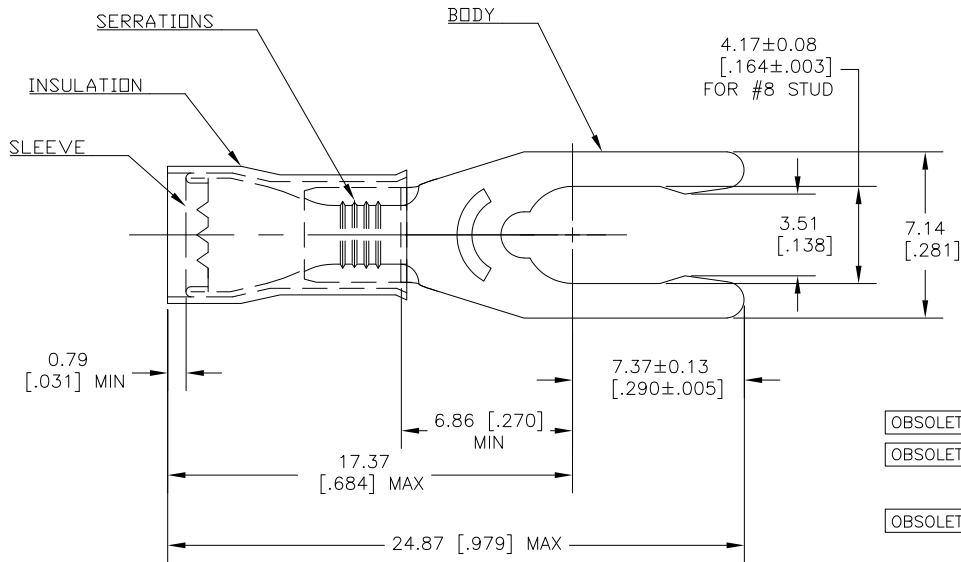

	.115-.170	100	LOOSE PIECE, BOX	9-52421-1
	.105-.150	100	LOOSE PIECE, BOX	8-52421-1
OBSOLETE	.115-.170	100	ON TAPE, SM BOX	52421-5
OBSOLETE	.115-.170	1000	ON TAPE, LG BOX	52421-4
	.115-.170	5000	ON TAPE, REEL	52421-3
OBSOLETE	.105-.150	5000	ON TAPE, REEL	52421-2
	.115-.170	--	LOOSE PIECE	52421-1
	.105-.150	--	LOOSE PIECE	52421
	DIM "A"	QTY	PACKAGE TYPE	PART NO

THIS DRAWING IS A CONTROLLED DOCUMENT.		DWN jr_ruth 14MAY10		
DIMENSIONS: MM [ INCHES ]		CHK TOM MICHELUTTI 14MAY10		
TOLERANCES UNLESS OTHERWISE SPECIFIED: 0 PLC ± - 1 PLC ± - 2 PLC ± 0.2 [.008] 3 PLC ± - 4 PLC ± - ANGLES ± 5°		APVD TOM MICHELUTTI 14MAY10	NAME	
		PRODUCT SPEC	TERMINAL, PIDG, SPRING SPADE, WIRE SIZE: 16-14	
MATERIAL		APPLICATION SPEC	SIZE	RESTRICTED TO
		WEIGHT	CAGE CODE	DRAWING NO
			A3	00779
		C=52421		
		CUSTOMER DRAWING		SCALE 6:1 SHEET 1 OF 1 REV H2