

4

3

2

1

THIS DRAWING IS UNPUBLISHED. RELEASED FOR PUBLICATION
 © COPYRIGHT - By - ALL RIGHTS RESERVED.

LOC	DIST	REVISIONS			
P	LTR	DESCRIPTION	DATE	DWN	APVD
G	14	H1	REVISED PER ECO-11-004917	11MAR11	RK HMR

AMP WIRE RANGE	Listed	LR7189 Certified
12-10 AWG SOLID OR STRANDED	12-10 AWG SOLID OR STRANDED	12-10 AWG SOLID OR STRANDED

- 1 STAMP 10S AMP 12-10* APPROX AS SHOWN
- 2 WIRE INSULATION DIA .150-.250
- 3 TONGUE MATERIAL THICKNESS .039±.002
- 4 MATERIAL: BODY - PHOS BRONZE PER ASTM B103
PLASTIC SLEEVE - NYLON, COLOR-YELLOW
METAL SLEEVE - COPPER PER ASTM B152
- 5 FINISH: BODY - TIN PLATE PER ASTM B545
METAL SLEEVE - TIN PLATE PER ASTM B545
- 6 DIMENSION APPLIES FROM EDGE OF METAL WIRE BARREL TO CENTER OF STUD.

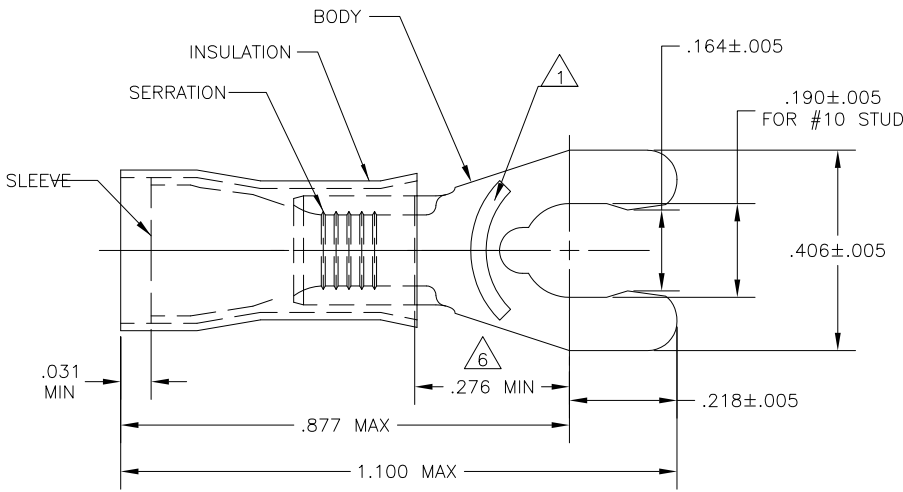

100	LOOSE PC, BOX	8-52943-1
1	ON TAPE	52943-1
1	LOOSE PIECE	52943
QTY	PACKAGE TYPE	PART NO

THIS DRAWING IS A CONTROLLED DOCUMENT.

DIMENSIONS: INCHES	TOLERANCES UNLESS OTHERWISE SPECIFIED: 0 PLC ± - 1 PLC ± - 2 PLC ± - 3 PLC ± .008 4 PLC ± - ANGLES ± 5°	DWN jr_ruth 20MAR07	TE Connectivity	
		CHK T MICHELUTTI 20MAR07	NAME TERMINAL, SPRING SPADE, STUB, PIDG WIRE SIZE: 12-10	
MATERIAL	FINISH	APVD T MICHELUTTI 20MAR07	SIZE A3	CAGE CODE 00779
		PRODUCT SPEC	DRAWING NO C-52943	RESTRICTED TO
		APPLICATION SPEC	WEIGHT	SCALE 5:1
			CUSTOMER DRAWING	SHEET 1 of 1 REV H1