

4 3 2 1
 DRAWING MADE IN THIRD ANGLE PROJECTION
 THIS DRAWING IS UNPUBLISHED. RELEASED FOR PUBLICATION
 © COPYRIGHT 19 BY AMP INCORPORATED. ALL INTERNATIONAL RIGHTS RESERVED.

LOC	DIST	P	F	ZONE	LTR	DESCRIPTION	DATE	APPD
G	14				C	REV, RDRW, & SM PKG PER 0720-0040-93	3-28-93	APD

METRIC
 DIMENSIONS LISTED IN mm [INCHES]

AMP WIRE RANGE	UL E13288 Listed
12-10 AWG SOLID OR STRANDED	12-10 AWG STRANDED
UL LR7189 Certified	MILITARY P/N AND CLASS
12-10 AWG SOLID OR STRANDED	NOT APPLICABLE

⚠ STAMP 8S AMP 12-10* APPROX AS SHOWN
 8S INDICATES STUD SIZE

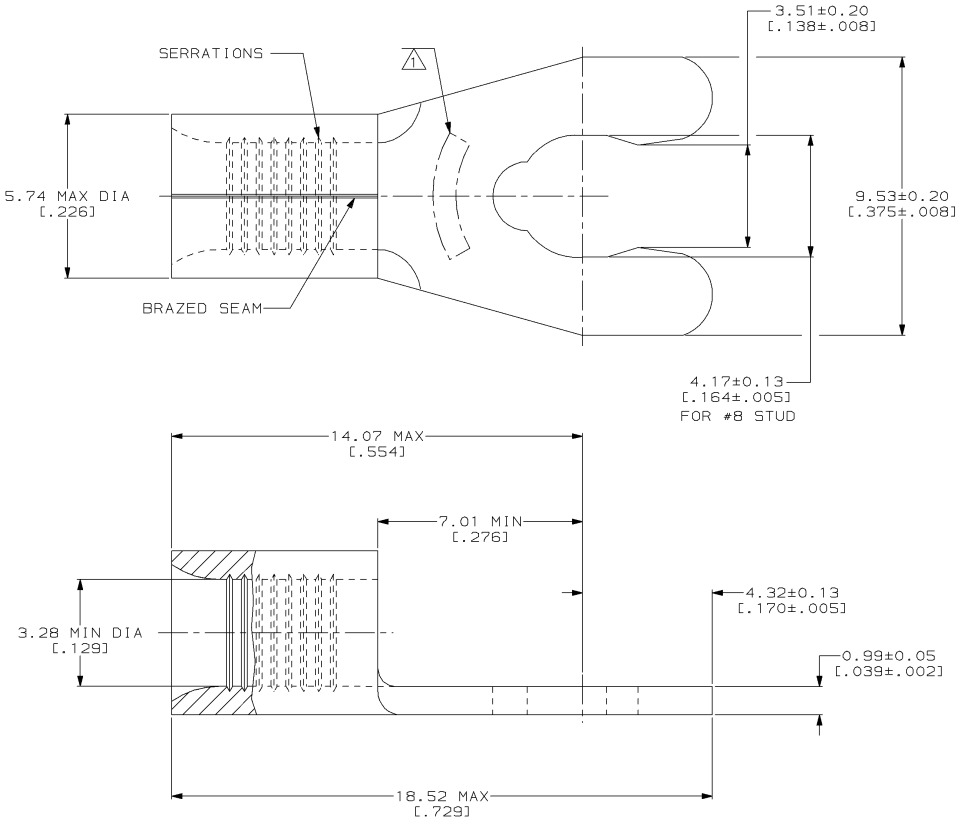

QUANTITY	PACKAGING TYPE	PART NO
50	LOOSE PIECE, BOX	8-53127-2
2500	ON TAPE	53127-2
---	LOOSE PIECE	53127-1

AMP INCORPORATED
CUSTOMER SERVICE SYSTEMS

FOR ADDITIONAL PRODUCT INFORMATION OR COPIES OF DRAWINGS AND TECHNICAL DOCUMENTS	PRODUCT INFORMATION CENTER 1-800-522-6752
FOR APPLICATION TOOLING INFORMATION	TOOLING ASSISTANCE CENTER 1-800-722-1111
FOR ORDER ENTRY	1-800-526-5142

MAX RECOMMENDED OPERATING TEMPERATURE:
 170°C MAX

VOLTAGE RATING:
 NOT APPLICABLE

WIRE CROSS SECTIONAL AREA RANGE:
 2.62-6.64mm² [5,180-13,100] CIR MILS
 SOLID OR STRANDED

THIS DRAWING IS A CONTROLLED DOCUMENT FOR AMP INCORPORATED. IT IS SUBJECT TO CHANGE AND THE CONTROLLING ENGINEERING ORGANIZATION SHOULD BE CONTACTED FOR THE LATEST REVISION.

DO NOT SCALE PRINT.
 UNLESS SPECIFIED DIMENSIONS IN mm (INCHES) TOLERANCES ON:
 2 PLC DEC ± -
 3 PLC DEC ± -
 ANGLES ± -

MATERIAL:
 PHOSPHOR BRONZE PER ASTM B-103 ANNEALED

FINISH:
 T1N PLATE 0.00254 [0.00100] MIN THK PER MIL-T-10727

DR 3-28-93
 TA BRINKMAN

CHK 3-29-93
 DA PATTERSON

APPD 3-28-93
 DE MILLER

APPD 3-28-93
 JL MECKLEY

APPLICATION SPEC
 -

WEIGHT
 -

AMP AMP Incorporated
 Harrisburg, PA 17105-3608

NAME
TERMINAL, SHORT SPRING SPADE, SOLISTRAND™

SIZE: CAGE CODE: DRAWING NO:
 © 00779 ©=53127

SCALE 10:1 SHEET 1 OF 1

AMP 1471-6 REV 3-92
 10_SEP_1993 13:05:25 AMP26463 <U5128A>DEPT1123>DWG1123>U_SQ1STRAND>U_INL_INE

CUSTOMER DRAWING