

4

3

2

1

THIS DRAWING IS UNPUBLISHED. RELEASED FOR PUBLICATION
 © COPYRIGHT - BY TYCO ELECTRONICS CORPORATION. ALL RIGHTS RESERVED.

| LOC | DIST | REVISIONS | | | |
|-----|------|-------------|-------------------------|----------|-------|
| P | LTR | DESCRIPTION | DATE | DWN | APVD |
| GP | 00 | A | REV PER EC 0S12-0573-04 | 05-04-05 | JA SF |

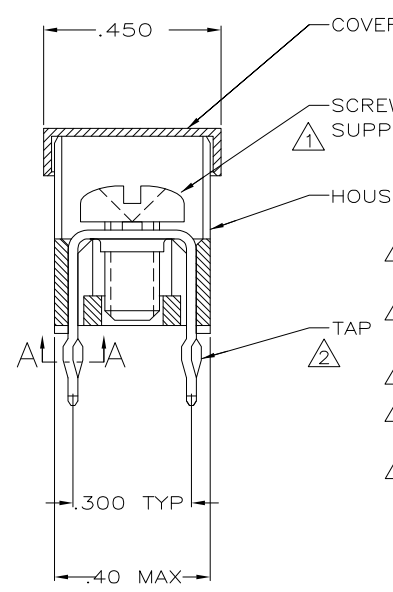
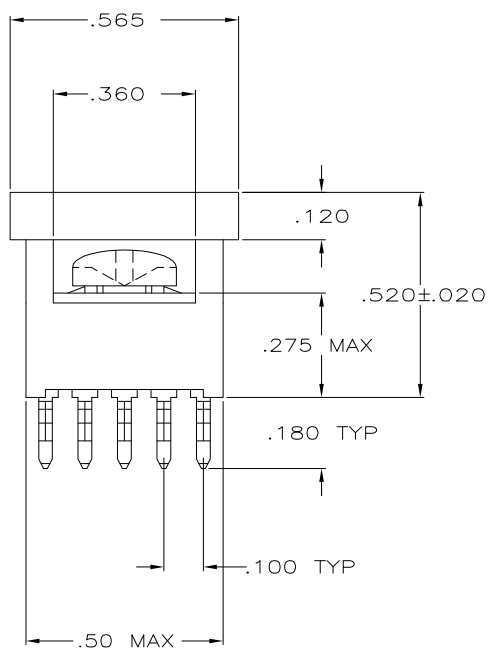

- ① TO PREVENT THREAD STRIPPING, SCREW TORQUE SHOULD NOT EXCEED 9 IN LBS.
 - ② TAP HOLE IS 6-32UNC-2B, TWO MIN THREADS.
 - ③ PACKAGED BULK.
 - ④ HOUSING: NYLON. TAP: COPPER ALLOY 725, .025 THICK
 - ⑤ TAP: .000150 MATTE TIN OVER .000050 NICKEL
6. REFERENCE APPLICATION SPECIFICATION 114-11000 FOR DRILL HOLE SIZES AND FINISHES.

.050±.005 DIA

SECTION A-A
 SCALE 10:1
 10 PLACES

| | | | |
|-----------|---------------------------|-------|-----------|
| ③ | YES | YES | 5055557-4 |
| ③ | YES | NO | 5055557-3 |
| PACKAGING | HOUSING AND TAP ASSEMBLED | SCREW | PART NO. |

THIS DRAWING IS A CONTROLLED DOCUMENT.

| | | | | |
|--------------------|--|---------------------------------------|--|--------------------|
| DIMENSIONS: INCHES | TOLERANCES UNLESS OTHERWISE SPECIFIED: | OWN J. ALCORTA - DOCK5 05-04-05 | Tyco Electronics Corporation Harrisburg, PA 17105-3608 | |
| 0 PLC ± - | 1 PLC ± - | CHK A. FRANTUM 05-04-05 | APVD S. FLICKINGER 05-04-05 | |
| 2 PLC ± - | 3 PLC ± .010 | NAME TAP ASSEMBLY, POWER DISTRIBUTION | | |
| 4 PLC ± - | ANGLES ± - | PRODUCT SPEC 108-11030 | | |
| MATERIAL ④ | FINISH ⑤ | APPLICATION SPEC 114-11000 | | |
| | | WEIGHT - | SIZE A3 | CAGE CODE 00779 |
| | | DRAWING NO C=5055557 | | RESTRICTED TO - |
| CUSTOMER DRAWING | | | SCALE 4:1 | SHEET 1 OF 1 REV A |