

THIS COPY IS PROVIDED ON A RESTRICTED BASIS AND IS NOT TO BE USED IN ANY WAY DETRIMENTAL TO THE INTERESTS OF PANDUIT CORP.

PANDUIT PART #	PK	STUD SIZE	DIMENSIONS in.				
			A $\pm .03$	W $\pm .01$	C $\pm .02$	M $\pm .03$	H $\pm .01$
PV6-8R	-E -T	#8	1.61 (40.89)	.47 (11.94)	.43 (10.92)	1.38 (35.05)	.18 (4.57)
PV6-10R	-X -T	#10	1.62 (41.15)	.47 (11.94)	.43 (10.92)	1.38 (35.05)	.20 (5.08)
PV6-14R	-X -T	1/4"	1.65 (41.91)	.47 (11.94)	.48 (12.19)	1.38 (35.05)	.27 (6.86)
PV6-56R	-X -T	5/16"	1.74 (44.20)	.62 (15.75)	.53 (13.46)	1.44 (36.58)	.33 (8.38)
PV6-38R	-X -T	3/8"	1.74 (44.20)	.62 (15.75)	.51 (12.95)	1.44 (36.58)	.40 (10.16)
PV6-12R	-X -T	1/2"	1.84 (46.74)	.82 (20.83)	.51 (12.95)	1.44 (36.58)	.52 (13.21)

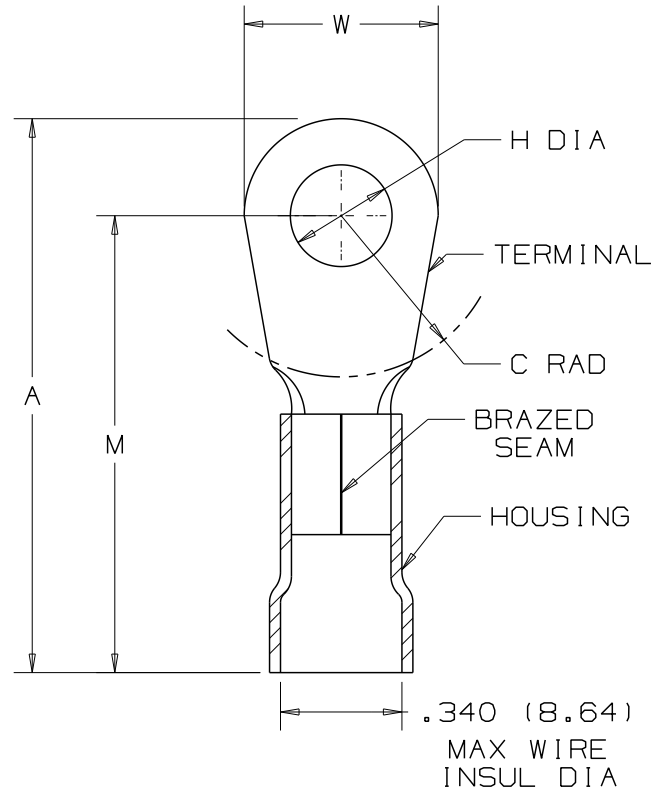

NOTES:

- UL LISTED FOR:
  - 600V MAX VOLTAGE RATING
  - 221° F (105° C) MAX TEMP RATING
  - #6 AWG STRANDED COPPER WIRE
- PACKAGE QTY: STD. PKG. -X=10  
STD. PKG. -E=20  
BULK PKG. -T=200
- MATERIAL:
  - STAMPING - .045" (1.14) THK COPPER, TIN PLATED
  - HOUSING - VINYL, BLUE
- DIMENSIONS IN BRACKETS ARE IN MILLIMETERS
- INSTALLATION TOOL: CT-720
- WIRE STRIP LENGTH: 7/16 <sup>+1/32</sup> <sub>-0</sub> (11.1 <sup>+.8</sup> <sub>-0</sub>)



LISTED  
587H  
E52164

05	1/11	SRB		ADDED PACKAGING CODE X=10				<p>TINLEY PARK, ILLINOIS</p> <p>#6 BARREL VINYL INSULATED RING TONGUE .340 (8.64) MAX. WIRE INSUL. DIAMETER</p>
04	1/01	KMD		CAD FILE SPEC. WAS N41218AA_PCD_03				
03	10/94	TH		UPDATED NOTES AND DIMENSIONS	02557			
02	7-88	DW		REDRAWN WITH REVISIONS				
REV	DATE	BY	CHK	DESCRIPTION	ECN #	CUST	PM	DRAWN BY: DAW CHK'D: SCALE: NONE DRAWING NO.: A41218