

THIS COPY IS PROVIDED ON A RESTRICTED BASIS AND IS NOT TO BE USED IN ANY WAY DETRIMENTAL TO THE INTERESTS OF PANDUIT CORP.

PANDUIT PART NUMBER	STUD SIZE	DIMENSIONS in.				
		A ±.03	W ±.01	C ±.02	M ±.03	H ±.01
PN12-6HDR	#6	1.06 (26.92)	.31 (7.87)	.35 (8.89)	.91 (23.11)	.15 (3.81)
PN12-8HDR	#8	1.06 (26.92)	.31 (7.87)	.35 (8.89)	.90 (22.86)	.17 (4.32)
PN12-10HDR	#10	1.09 (27.69)	.37 (9.40)	.33 (8.38)	.89 (22.61)	.20 (5.08)
PN12-14HDR	1/4"	1.24 (31.50)	.52 (13.21)	.42 (10.67)	.98 (24.89)	.27 (6.86)
PN12-56HDR	5/16"	1.24 (31.50)	.52 (13.21)	.42 (10.67)	.98 (24.89)	.33 (8.38)
PN12-38HDR	3/8"	1.30 (33.02)	.58 (14.73)	.46 (11.68)	1.02 (25.91)	.39 (9.91)

NOTES:

- UL LISTED AND CSA CERTIFIED FOR:
 - 600V. MAX. VOLTAGE RATING (1000V MAX IN SIGNS, FIXTURES, & LUMINAIRES)
 - #16-12 AWG SOLID OR STRANDED COPPER WIRE
 - 221° F (105° C) MAX. TEMP. RATING
- MATERIAL:
 - STAMPING - .05" (1.27) THK COPPER, TIN PLATED
 - HOUSING - NYLON, YELLOW
 - SLEEVE - BRASS, TIN PLATED
- PACKAGE QTY: STD. PKG. L=50
BULK PKG. D-500
- DIMENSIONS IN BRACKETS ARE IN MILLIMETERS
- INSTALLATION TOOLS:
 - UL LISTED AND CSA CERTIFIED: CT-550
CT-1550, CT1551
 - PANDUIT APPROVED: CT-460
- WIRE STRIP LENGTH: 9/32 ^{9/32} (7.1¹⁶)

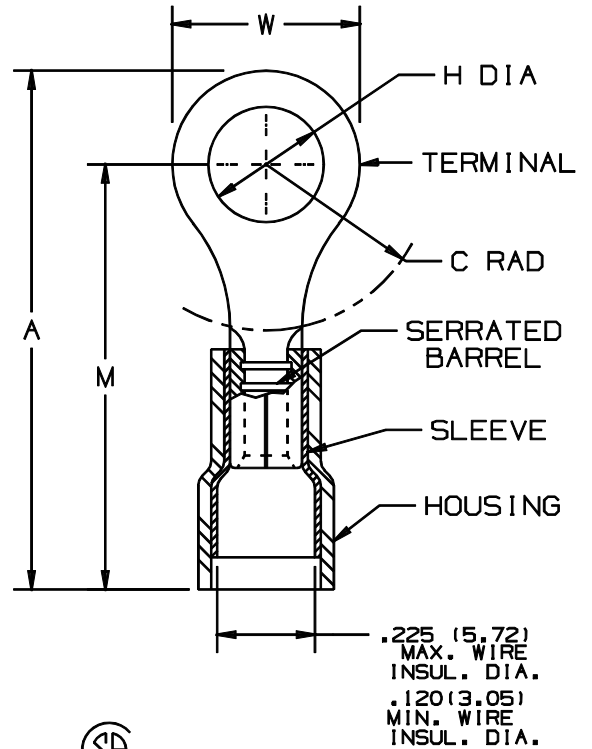

LISTED
587H
E52164



CERTIFIED
LR31212

A41283_04

04	1/01	RM		FILESPEC WAS N41283AA_PCD_03					CORP.	TINLEY PARK, ILLINOIS	
03	12/96	JB		ADDED DIM., "MIN. WIRE INSUL. DIA."	05432						
02	6/96	JKD	RLS	CHANGED NOTES, CHANGED TABLE TO REFLECT CURRENT PART	04721	LA	TJBU	#16-12 BARREL NYLON INSULATED HEAVY DUTY RING TONGUE, .225 (5.72) MAX. WIRE INSULATION DIAMETER			
1	7-88	DW		REDRAWN WITH REVISIONS							
REV	DATE	BY	CHK	DESCRIPTION	ECN	CUST	PM	DRAWN BY DAW	CHK'D LA	SCALE NONE	DRAWING NO. A41283